

KENWOOD

Document Copyrights

Copyright 2006 by Kenwood Corporation. All rights reserved.

No part of this manual may be reproduced, translated, distributed, or transmitted in any form or by any means, electronic, mechanical, photocopying, recording, or otherwise, for any purpose without the prior written permission of Kenwood.

Disclaimer

While every precaution has been taken in the preparation of this manual, Kenwood assumes no responsibility for errors or omissions. Neither is any liability assumed for damages resulting from the use of the information contained herein. Kenwood reserves the right to make changes to any products herein at any time for improvement purposes.

文档版权信息

Kenwood Corporation 拥有版权 2006。保留所有权利。

未经 Kenwood 公司预先书面同意，无论出于何种目的，均不得以任何形式或任何方式包括电子、机械、影印、录音或以其他方式复制、翻译、分发或传播本手册的任何部分。

免责声明

Kenwood 公司在准备本文档时已采取所有必要的预防措施，恕不对错误或疏漏承担任何责任，也不对因使用本文中所含的信息而导致的损害负责。Kenwood 公司保留出于改进的需要而随时对文中的产品信息做出更改的权利。

TK-3207

SERVICE MANUAL / 维修手册

C5 · C6 versions / C5 · C6 版

KENWOOD

Kenwood Corporation

© 2006-4 PRINTED IN JAPAN
B51-8688-10 (S) PDF

SUPPLEMENT II / 追补版 II

In the TK-3207 service manual (B51-8688-00), the TX-RX UNIT number and the destination number are incorrect.

This service manual substitutes for the TK-3207 service manual (B51-8688-00).

在TK-3207维修手册(B51-8688-00)里, TX-RX单元号和商品处理号是错误的。

本维修手册代替TK-3207维修手册(B51-8688-00)。



CONTENTS

GENERAL	2
SYSTEM SET-UP	3
REALIGNMENT	4
COMPONENTS DESCRIPTION	6
PARTS LIST	8
EXPLODED VIEW	14
PACKING	15
ADJUSTMENT	16
PC BOARD	
TX-RX UNIT (X57-6890-XX)	28
SCHEMATIC DIAGRAM	32
BLOCK DIAGRAM	36
LEVEL DIAGRAM	38
SPECIFICATIONS	39

Service Manual List

Title	Parts number	Remarks	Destination
TK-3207	B51-8680-00		M, C, C2
TK-3207	B51-8688-00	SUPPLEMENT	C5, C6
TK-3207	B51-8688-10 (This service manual)	SUPPLEMENT II	C5, C6

维修手册表

型号	零件号码	备注	类型
TK-3207	B51-8680-00		M, C, C2
TK-3207	B51-8688-00	追补版	C5, C6
TK-3207	B51-8688-10 (本维修手册)	追补版 II	C5, C6

概述.....	2	调整.....	16
系统体系.....	3	PC 板	
模式组合.....	4	TX - RX 单元 (X57-6890-XX).....	28
元件说明.....	6	原理图.....	32
零件表.....	8	方块图.....	36
部件分解图.....	14	电平图.....	38
包装.....	15	规格.....	封底

GENERAL / 概述

INTRODUCTION

SCOPE OF THIS MANUAL

This manual is intended for use by experienced technicians familiar with similar types of commercial grade communications equipment. It contains all required service information for the equipment and is current as of the publication date. Changes which may occur after publication are covered by either Service Bulletins or Manual Revisions. These are issued as required.

ORDERING REPLACEMENT PARTS

When ordering replacement parts or equipment information, the full part identification number should be included. This applies to all parts : components, kits, or chassis. If the part number is not known, include the chassis or kit number of which it is a part, and a sufficient description of the required component for proper identification.

PERSONAL SAFETY

The following precautions are recommended for personal safety:

- DO NOT transmit until all RF connectors are verified secure and any open connectors are properly terminated.
- SHUT OFF and DO NOT operate this equipment near electrical blasting caps or in an explosive atmosphere.
- This equipment should be serviced by a qualified technician only.

引言

本手册的范围

本手册是提供给熟悉通信专业并且具有维修经验的技术人员使用的。它包括了维修该设备所需要的全部资料和现行出版日期。在出版后如果发生变动,则根据需要使用《维修通报》或《手册修订本》进行补充。

替换零件的订购

当订购替换零件或设备资料时,应注明完整的零件识别号码。所有的零件均有识别号码:元件,组件或机壳。如果不知道零件的号码,为了正确地识别,必须注明此元件所属的机壳或组件的号码,并对元件进行充分的说明。

个人安全

为了个人的安全,请注意下列事项:

- 在没有认真核实所有射频插头之前或有任何一个打开的插头没有连接到相应端子上的情况下,均不要发射。
- 在电爆管附近或在易燃性气体环境中,必须关掉电源,不要操作本设备。
- 本设备只应该由有资格的技术人员来维修。

GENERAL / 概述

SERVICE

This transceiver is designed for easy servicing. Refer to the schematic diagrams, printed circuit board views, and alignment procedures contained within.

维修服务

为了便于维修本设备，建立了完整的维修服务体系，提供了包括原理图，印刷电路板图和调整步骤在内的资料供参考。

Unit		TX-RX Unit	Frequency range	Remarks
Model & destination				
TK-3207	C5	X57-6890-25	370~390MHz	IF1 : 38.85MHz LOC : 38.4MHz
	C6	X57-6890-24	350~370MHz	

单元		TX-RX 单元	频率范围	备注
型号和类型				
TK-3207	C5	X57-6890-25	370~390MHz	IF1 : 38.85MHz LOC : 38.4MH
	C6	X57-6890-24	350~370MHz	

SYSTEM SET-UP / 系统体系

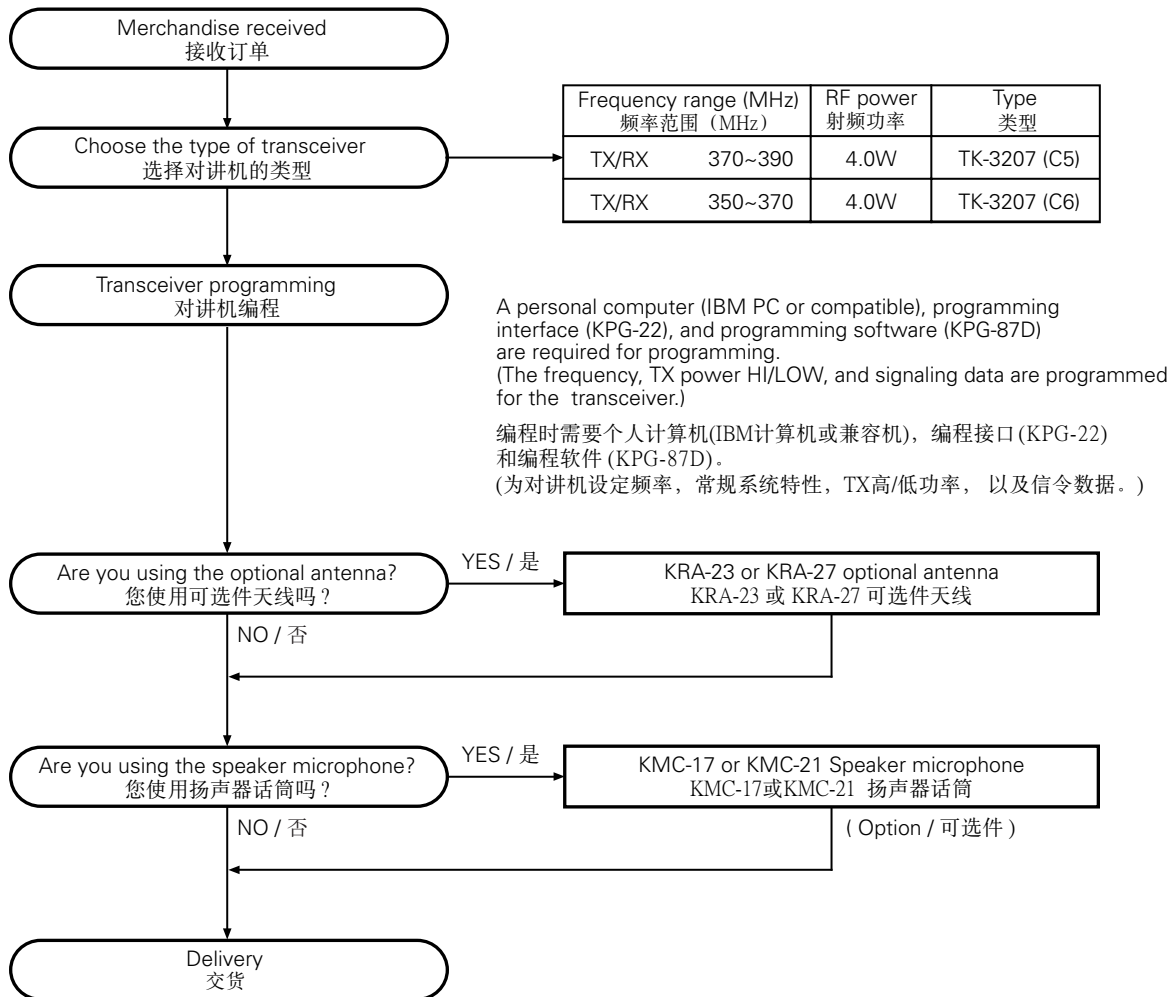

REALIGNMENT / 模式组合

1. Clone Mode**1-1. Outline**

"Clone Mode" copies the transceiver data to another transceiver.

The dealer can copy the transceiver data to another transceiver even without the use of a personal computer.

1-2. Example

The transceiver can copy the programming data to one or more transceivers via RF communication.

The clone source and clone target/s must be in Clone mode.

1-3. Operation

1. To switch the clone target/s to Clone mode, press and hold the [PTT] and [Side2] keys while turning the transceiver power ON.
2. Wait for 2 seconds. The LED will light orange and the transceiver will announce "Clone".
3. Select a channel table number using Side1(increment channel table) and Side2(decrement channel table) keys.
4. To switch the clone source to Clone mode, press and hold the [PTT] and [Side2] keys while turning the transceiver power ON.
5. Wait for 2 seconds. The LED will light orange and the transceiver will announce "Clone".
6. Select the same channel table number as the clone target/s.
7. Press [PTT] on the clone source to begin data transmission. When the clone target starts to receive data, the LED will light green.
When the clone source finishes sending data, a "confirmation" tone will sound.
If data transmission fails while cloning, an "error" tone will sound from the Target unit.
8. If the cloning fails, no data will be available in the Target unit when it is returned to User mode.
9. When the cloning is successful, the Target unit's "Scan" and "Key lock" functions will return to their default values (Scan = OFF, Key lock = OFF).

Notes:

- The dealer can clone data to two or more transceivers by repeating the above procedures.
- If the transceivers Clone Mode is configured as "Disabled", the transceiver cannot enter Clone mode.
- The table shown below will cover the frequency tables used for wireless cloning.
- Clone mode cannot be entered in battery low state.
- A unit cannot be a "Source Unit" if it is unprogrammed. If [PTT] is pressed, an "error" tone will sound.
- The language used in cloning depends on the "Model type" setting, not the FPU setting. C, C2, C5 and C6 type TK-3207 transceivers will use Chinese. Other types English.
- Once a unit is set to be the Source, it cannot be a target after the data has been transmitted. This protects the data in the Source unit.

1. 复制模式**1-1. 概要**

“复制模式”可以将一台对讲机的数据复制到其它的对讲机。经销商甚至不使用个人电脑也可以将一台对讲机的数据复制到其它的对讲机。

1-2. 例:

对讲机可以通过 RF 通信复制编程数据到一台或更多的对讲机。

复制主机和复制子机必须处于复制模式。

1-3. 操作方法

1. 将子机切换到复制模式，持续按[PTT] 键和 [侧面2] 键，然后打开对讲机电源的开关。
2. 等待2秒。LED将呈橘黄色并且对讲机将发出"复制"的声音。
3. 用侧面1 (频道表递增) 键和侧面2 (频道表递减) 键选择频率表号码。
4. 将主机切换到复制模式，持续按[PTT] 键和 [侧面2] 键，然后打开对讲机电源的开关。
5. 等待2秒。LED将呈橘黄色并且对讲机将发出"复制"的声音。
6. 选择与复制子机相同的频率表号码。
7. 按复制主机上的 [PTT]，开始数据传输。
当复制子机开始接收数据时，LED 将呈绿色。
当复制主机完成传送数据时，将发出一个“确认”音。
如果在复制过程中数据传输失败，子机将发出一个"错误"音。
8. 如果复制失败，子机回到用户模式时数据随即消失。
9. 当复制成功时，子机的"扫描"和"键锁定"功能将回到它们的初始值 (扫描 =OFF, 键锁定 =OFF)

注释:

- 经销商可以反复上述过程复制数据到2个或更多的对讲机。
- 如果对讲机复制模式被设置为“无效”，则对讲机不能进入复制模式。
- 下表包含了无线复制用的频率表。
- 当电池处于低电压状态时不能进入复制模式。
- 如果对讲机是非编程的它将不能成为主机。如果按[PTT]，将发出一个"错误"音。
- 复制时所用的语言是根据"样机类别"设置，而不是FPU设置，TK-3207的C, C2, C5和C6类别的对讲机用中文，其它类别用英文。
- 对讲机一旦被设置为主机，数据传送以后，它就不能成为子机。这是为了保护主机里的数据。

REALIGNMENT / 模式组合

- Electronic interface may cause a failure in data transfer during Wireless Clone, such as when waveforms or electromagnetics are being performed at the workbench.
- Clone mode can be used ONLY by the authorized service personnel.
- The Clone mode setting must be configured as "Disable" before being delivered to the end-user.
- To clone, replace the antenna from both the source transceiver and the target transceiver with a dummy load.
- The transmit output power is automatically set to Low in Clone mode.
- 在无线复制的数据传输过程中，例如在工作台产生的电波或电磁干扰有可能引起传输失败。
- 复制模式可以仅被批准的服务人员使用。
- 在交付给最终用户之前，复制模式设置必须被设置为“无效”。
- 为了复制，将模拟负载代替主对讲机和子对讲机的天线。
- 在复制模式，发射功率自动设定为低。

Clone Frequency Table

Type	C5	C6
Operating Frequency (MHz)	370~390	350~370
Clone Frequency Table		
1	370.000	350.000
2	371.000	351.000
3	372.000	352.000
4	373.000	353.000
5	374.000	354.000
6	375.000	355.000
7	376.000	356.000
8	377.000	357.000
9	378.000	358.000
10	379.000	359.000
11	380.000	360.000
12	381.000	361.000
13	382.000	362.000
14	383.000	363.000
15	384.000	364.000
16	385.000	365.000
17	386.000	366.000
18	387.000	367.000
19	388.000	368.000
20	389.000	369.000

复制频率表

类型	C5	C6
操作频率 (MHz)	370~390	350~370
复制频率表		
1	370.000	350.000
2	371.000	351.000
3	372.000	352.000
4	373.000	353.000
5	374.000	354.000
6	375.000	355.000
7	376.000	356.000
8	377.000	357.000
9	378.000	358.000
10	379.000	359.000
11	380.000	360.000
12	381.000	361.000
13	382.000	362.000
14	383.000	363.000
15	384.000	364.000
16	385.000	365.000
17	386.000	366.000
18	387.000	367.000
19	388.000	368.000
20	389.000	369.000

COMPONENTS DESCRIPTION / 元件说明

TX-RX UNIT (X57-6890-XX)

Ref. No.	Use/Function	Operation/Condition
IC1	IC	PLL system
IC101	IC	Comparator (APC)
IC201	IC	FM IF system
IC301	IC	Audio processor
IC302	IC	AF AMP
IC401	IC	Voltage regulator/ 5V
IC402	IC	Voltage regulator/ 5V
IC403	IC	Voltage detector / Reset
IC404	IC	Voltage detector / INT
IC405	IC	Microprocessor
IC406	IC	EEPROM
Q1	Transistor	Tripler
Q2	Transistor	PLL IC f_in AMP
Q3	FET	VCO / RX
Q4	FET	VCO / TX
Q5	Transistor	DC switch / TX VCO
Q6	Transistor	RF Buffer AMP
Q7	Transistor	DC switch / RX VCO
Q8	Transistor	Ripple filter
Q9	Transistor	RF AMP
Q100	Transistor	RF AMP
Q101	FET	RF AMP
Q102	FET	TX Drive AMP
Q103	FET	TX Final AMP
Q104	Transistor	APC switch
Q105	FET	APC switch
Q107	Transistor	APC switch
Q108	FET	APC switch
Q109	Transistor	APC switch
Q202	Transistor	W/N switch / RX
Q203	Transistor	IF AMP
Q204	FET	Mixer
Q205	FET	RF AMP
Q301	Transistor	W/N switch / TX
Q302	Transistor	MIC AGC
Q303	Transistor	DC switch / SP Mute
Q304	Transistor	DC switch
Q305	Transistor	DC switch / SP Mute
Q306	FET	SP Mute switch
Q316	FET	SP Mute switch
Q401	Transistor	LED switch / Red
Q402	Transistor	LED switch / Green
Q403	FET	5T switch
Q404	FET	5R switch
Q405	Transistor	5C switch
Q407	FET	Beat Shift switch
Q408	FET	Beat Shift switch
Q901	FET	W/N Switch/ TX
D1	Diode	Ripple Filter
D2	Variable capacitance diode	Frequency control / TX VCO
D3	Variable capacitance diode	Frequency control / RX VCO

TX-RX 单元 (X57-6890-XX)

编号	使用 / 功能	操作 / 状态
IC1	IC	PLL 系统
IC101	IC	比较器 (APC)
IC201	IC	FM IF 系统
IC301	IC	音频处理器
IC302	IC	AF 放大器
IC401	IC	电压管理器 / 5V
IC402	IC	电压管理器 / 5V
IC403	IC	电压检测器 / 复位
IC404	IC	电压检测器 / INT
IC405	IC	微处理器
IC406	IC	EEPROM
Q1	晶体管	三倍频器
Q2	晶体管	PLL IC f_in 放大器
Q3	场效应管	VCO / RX
Q4	场效应管	VCO / TX
Q5	晶体管	DC 开关 / TX VCO
Q6	晶体管	RF 缓冲放大器
Q7	晶体管	DC 开关 / RX VCO
Q8	晶体管	触发滤波器
Q9	晶体管	RF 放大器
Q100	晶体管	RF 放大器
Q101	场效应管	RF 放大器
Q102	场效应管	TX 驱动放大器
Q103	场效应管	TX 终端放大器
Q104	晶体管	APC 开关
Q105	场效应管	APC 开关
Q107	晶体管	APC 开关
Q108	场效应管	APC 开关
Q109	晶体管	APC 开关
Q202	晶体管	W/N 开关 / RX
Q203	晶体管	IF 放大器
Q204	场效应管	混频器
Q205	场效应管	RF 放大器
Q301	晶体管	W/N 开关 / TX
Q302	晶体管	MIC AGC
Q303	晶体管	DC 开关 / SP 静音
Q304	晶体管	DC 开关
Q305	晶体管	DC 开关 / SP 静音
Q306	场效应管	SP 静音开关
Q316	场效应管	SP 静音开关
Q401	晶体管	LED 开关 / 红
Q402	晶体管	LED 开关 / 绿
Q403	场效应管	5T 开关
Q404	场效应管	5R 开关
Q405	晶体管	5C 开关
Q407	场效应管	拍频偏移开关
Q408	场效应管	拍频偏移开关
Q901	场效应管	W/N 开关 / TX
D1	二极管	触发滤波器
D2	可变电容二极管	频率控制 / TX VCO
D3	可变电容二极管	频率控制 / RX VCO

COMPONENTS DESCRIPTION / 元件说明

Ref. No.	Use/Function	Operation/Condition
D4	Variable capacitance diode	Frequency control / TX VCO
D5	Variable capacitance diode	Frequency control / RX VCO
D6	Variable capacitance diode	Frequency control / TX VCO
D7	Variable capacitance diode	Frequency control / TX VCO
D8	Variable capacitance diode	Frequency control / RX VCO
D9	Variable capacitance diode	Frequency control / RX VCO
D10	Variable capacitance diode	Modulator
D11	Diode	Current steering
D101	Diode	TX/RX RF switch
D102	Zener diode	APC protect
D103	Diode	ANT switch
D104	Diode	ANT switch
D106	Diode	ANT switch
D122	Diode	ANT switch
D202	Diode	TX/RX RF switch
D203	Variable capacitance diode	RF BPF tuning
D204	Variable capacitance diode	RF BPF tuning
D205	Variable capacitance diode	RF BPF tuning
D206	Variable capacitance diode	RF BPF tuning
D210	Variable capacitance diode	RF BPF tuning
D301	Diode	Detector
D302	Diode	Detector
D303	Diode	Isolation
D401	Diode	5V Protection
D402	Diode	Reverse Protection
D403	LED	LED/ Red
D404	LED	LED/ Green
D405	Zener diode	Limiter of QT encode deviation

编号	使用 / 功能	操作 / 状态
D4	可变电容二极管	频率控制 / TX VCO
D5	可变电容二极管	频率控制 / RX VCO
D6	可变电容二极管	频率控制 / TX VCO
D7	可变电容二极管	频率控制 / TX VCO
D8	可变电容二极管	频率控制 / RX VCO
D9	可变电容二极管	频率控制 / RX VCO
D10	可变电容二极管	调制器
D11	二极管	电流开关
D101	二极管	TX/RX RF 开关
D102	齐纳二极管	APC 保护
D103	二极管	ANT 开关
D104	二极管	ANT 开关
D106	二极管	ANT 开关
D122	二极管	ANT 开关
D202	二极管	TX/RX RF 开关
D203	可变电容二极管	RF BPF 调谐
D204	可变电容二极管	RF BPF 调谐
D205	可变电容二极管	RF BPF 调谐
D206	可变电容二极管	RF BPF 调谐
D210	可变电容二极管	RF BPF 调谐
D301	二极管	检测器
D302	二极管	检测器
D303	二极管	隔离
D401	二极管	5V 保护器
D402	二极管	反转保护器
D403	LED	LED / 红
D404	LED	LED / 绿
D405	齐纳二极管	QT 编码频偏限幅器

TK-3207

PARTS LIST / 零件表

* New Parts. △ indicates safety critical components.
 Parts without **Parts No.** are not supplied.
 Les articles non mentionnés dans le **Parts No.** ne sont pas fournis.
 Teile ohne **Parts No.** werden nicht geliefert.

L: Scandinavia K: USA P: Canada
 Y: PX (Far East, Hawaii) T: England E: Europe
 Y: AAFES (Europe) X: Australia M: Other Areas

TK-3207 (Y50-590X-XX) TX-RX UNIT (X57-6890-XX)

Ref. No.	Address	New parts	Parts No.	Description	Destination
TK-3207					
1	1A	*	A02-3851-33	CABINET ASSY(16CH)	
2	1A	*	A02-3858-23	CABINET	
3	3A	*	A10-4078-21	CHASSIS	
4	1B		A21-1644-13	DRESSING PANEL(16CH)	
6	2C		B09-0680-03	CAP(SP/MIC) ACCESSORY	
7	2B		B11-1817-04	ILLUMINATION GUIDE	
8	1B		B43-1156-04	BADGE	
10	1C	*	B62-1764-10	INSTRUCTION MANUAL	
11	1A		D10-0649-03	LEVER	
12	1A		D21-0863-04	SHAFT	
13	1A		D32-0441-03	STOPPER	
14	2A		E04-0451-05	RF COAXIAL RECEPTACLE(SMA)	
15	3B		E23-1253-04	TERMINAL(BATT-)	
16	2B		E37-0794-05	PROCESSED LEAD WIRE(SP+)	
17	2B		E37-0803-05	PROCESSED LEAD WIRE(SP-)	
18	3A		F20-3353-14	INSULATING SHEET(CHASSIS BATT+)	
19	2A		G01-4542-04	COIL SPRING(LEVER)	
20	1A		G01-4543-04	COIL SPRING(STOPPER)	
21	2B		G10-1330-04	FIBROUS SHEET(IC302:AUDIO IC)	
22	3A		G11-2622-04	SHEET(CHASSIS)	
23	3A		G11-4283-04	RUBBER SHEET(Q103:FINAL FET)	
24	2A		G11-4313-04	SHEET(MIC ELEMENT)	
25	1A	*	G11-4319-04	SHEET(PTT)	
26	2B		G11-4322-04	SHEET(VR)	C,C2
27	3A		G13-2033-04	CUSHION(TERMINAL BATT-)	
28	3B		G13-2034-14	CUSHION(TERMINAL BATT-)	
29	2B		G13-2037-04	CUSHION(CHASSIS VOL/CH)	
30	3A	*	G13-2038-14	CUSHION(CHASSIS-CERAMIC FILTER)	
31	2A		G13-2039-04	CUSHION(PCB-CERAMIC FILTER)	
32	3B	*	G13-2045-04	CUSHION(CHASSIS)	
33	2B	*	G13-2051-04	CUSHION(VCO)	
34	3A		G53-1604-03	PACKING(CHASSIS)	
35	3A		G53-1605-03	PACKING(TERMINAL BATT+)	
36	2B		G53-1606-03	PACKING(VOL/CH/LED)	
37	1B		G53-1607-03	PACKING(SP/MIC)	
38	2B		G53-1608-03	PACKING(SP)	
39	2A		G53-1609-14	PACKING(MIC ELEMENT)	
40	2B		G53-1610-04	PACKING(SMA)	
41	2D		H12-3158-05	PACKING FIXTURE	
42	1C		H25-0085-04	PROTECTION BAG (100/200/0.07)	
43	3D		H52-2055-02	ITEM CARTON CASE	
44	2D		J19-5472-03	HOLDER(SP/MIC) ACCESSORY	
45	2A		J19-5473-03	HOLDER ASSY(TERMINAL BATT+)	
46	2B		J21-8477-04	HARDWARE FIXTURE(VOL/CH)	
47	2B		J21-8478-04	HARDWARE FIXTURE(SP/MIC)	
48	2D		J29-0713-05	BELT CLIP ACCESSORY	
49	1D		J69-0352-05	HANDSTRAP ACCESSORY	
50	2B		J82-0092-05	FPC	
51	1A		K29-9307-03	BUTTON KNOB(SIDE1/SIDE2)	
52	1A		K29-9308-03	BUTTON KNOB(PTT)	

Ref. No.	Address	New parts	Parts No.	Description	Destination
53	1B		K29-9309-03	KNOB(VOL)	
54	1B		K29-9318-03	KNOB(CH)	
A	2B		N14-0808-04	CIRCULAR NUT(CH KNOB)	
B	2B	*	N14-0819-04	CIRCULAR NUT(VOL KNOB)	
C	2A,2B		N30-2604-46	PAN HEAD MACHINE SCREW(SMA)	
D	3A		N30-2606-46	PAN HEAD MACHINE SCREW(CHASSIS)	
E	2A,2B,3B		N83-2005-46	PAN HEAD TAPTITE SCREW(PCB)	
55	2D		N99-2043-05	SCREW SET ACCESSORY	
56	2B		R31-0653-05	VARIABLE RESISTOR(POWER SW/VOL)	
57	2B		S60-0427-05	ROTARY SWITCH(16CH)	
58	1B		T07-0369-05	SPEAKER	
59	1D		T90-0798-15	HELICAL ANTENNA ACCESSORY	C
59	1D		T90-0800-15	HELICAL ANTENNA ACCESSORY	C2
59	1D		T90-1035-05	HELICAL ANTENNA ACCESSORY	C5,C6
TX-RX UNIT (X57-6890-XX) -21: C -22: C2 -24: C6 -25: C5					
D403			B30-2156-05	LED(RED)	
D404			B30-2157-05	LED(YELLOW)	
C1			CK73HB1H332K	CHIP C 3300PF K	
C2			CK73HB1C682K	CHIP C 6800PF K	
C3			CK73GB1A105K	CHIP C 1.0UF K	
C4			CK73HB1C103K	CHIP C 0.010UF K	
C5			CK73HB1H102K	CHIP C 1000PF K	
C6			CK73HB1A104K	CHIP C 0.10UF K	
C7, 8			CC73HCH1H101J	CHIP C 100PF J	
C9			CC73HCH1H100D	CHIP C 10PF D	
C10			C92-0713-05	CHIP-TAN 10UF 6.3WV	
C11			CC73HCH1H101J	CHIP C 100PF J	
C12			CK73HB1H102K	CHIP C 1000PF K	
C13			CK73HB1A104K	CHIP C 0.10UF K	
C14			CK73HB1C103K	CHIP C 0.010UF K	
C15			CC73HCH1H100D	CHIP C 10PF D	
C16			CK73HB1H102K	CHIP C 1000PF K	
C17			CC73HCH1H470J	CHIP C 47PF J	
C18			CC73HCH1H180J	CHIP C 18PF J	
C19			CK73HB1A104K	CHIP C 0.10UF K	
C21			C92-0713-05	CHIP-TAN 10UF 6.3WV	
C22			C92-0502-05	CHIP-TAN 0.33UF 35WV	
C24			CK73HB1H102K	CHIP C 1000PF K	
C25			CC73HCH1H020B	CHIP C 2.0PF B	
C26			CC73HCH1H300J	CHIP C 30PF J	
C27			C92-0697-05	CHIP-TAN 3.3UF 16WV	
C29, 30			CK73HB1H471K	CHIP C 470PF K	
C32			C92-0001-05	CHIP C 0.1UF 35WV	
C33, 34			CK73HB1H102K	CHIP C 1000PF K	
C35			CC73HCH1H270J	CHIP C 27PF J	
C38			CC73HCH1H050B	CHIP C 5.0PF B	
C39			CK73GB1H332K	CHIP C 3300PF K	
C40			CC73HCH1H030B	CHIP C 3.0PF B	
C41			CK73GB1H682K	CHIP C 6800PF K	
C42			CC73HCH1H050B	CHIP C 5.0PF B	
C43			CC73HCH1H100C	CHIP C 10PF C	
C44			CK73HB1H471K	CHIP C 470PF K	

PARTS LIST / 零件表

TX-RX UNIT (X57-6890-XX)

Ref. No.	Address	New parts	Parts No.	Description	Destination	Ref. No.	Address	New parts	Parts No.	Description	Destination
C45			CK73GB1A105K	CHIP C 1.0UF K		C116			CC73GCH1H030B	CHIP C 3.0PF B	C2
C47			CC73HCH1H101J	CHIP C 100PF J		C116			CC73GCH1H110J	CHIP C 11PF J	C
C48			CK73HB1H471K	CHIP C 470PF K		C116			CC73GCH1H120J	CHIP C 12PF J	C5,C6
C49			CC73HCH1H101J	CHIP C 100PF J		C119			CK73GB1H471K	CHIP C 470PF K	
C50			CC73HCH1H100D	CHIP C 10PF D		C121			CC73GCH1H120J	CHIP C 12PF J	C2
C52			CC73HCH1H110J	CHIP C 11PF J	C2,C5,C6	C122			CC73GCH1H330J	CHIP C 33PF J	
C52			CC73HCH1H120J	CHIP C 12PF J	C	C123			CC73GCH1H330G	CHIP C 33PF G	
C53			CC73HCH1H040B	CHIP C 4.0PF B	C2	C124			CC73HCH1H100D	CHIP C 10PF D	
C53			CC73HCH1H050B	CHIP C 5.0PF B	C6	C125			CC73GCH1H060B	CHIP C 6.0PF B	C
C54			CC73HCH1H060B	CHIP C 6.0PF B	C,C5	C125			CC73GCH1H080B	CHIP C 8.0PF B	C2
C54			CC73HCH1H070B	CHIP C 7.0PF B	C2	C125			CC73GCH1H240J	CHIP C 24PF J	C5,C6
C54			CC73HCH1H090B	CHIP C 9.0PF B	C6	C126			C92-0004-05	CHIP-TAN 1.0UF 16WV	
C55			CC73HCH1H110J	CHIP C 11PF J	C5	C127			CC73GCH1H200J	CHIP C 20PF J	C
C55			CC73HCH1H120J	CHIP C 12PF J	C,C2	C128			CK73HB1H471K	CHIP C 470PF K	
C55			CC73HCH1H220J	CHIP C 22PF J	C6	C129			CK73GB1H471K	CHIP C 470PF K	
C56			CC73HCH1H050B	CHIP C 5.0PF B	C2						
C57			CC73HCH1H0R5B	CHIP C 0.5PF B	C2,C5,C6	C130			CK73HB1H471K	CHIP C 470PF K	
C58			CC73HCH1H060B	CHIP C 6.0PF B	C,C5	C132			CC73GCH1H200J	CHIP C 20PF J	C,C5,C6
C58			CC73HCH1H070B	CHIP C 7.0PF B	C2	C132			CC73GCH1H390J	CHIP C 39PF J	C2
C58			CC73HCH1H110J	CHIP C 11PF J	C6	C133			CK73GB1H471K	CHIP C 470PF K	
C59			CC73HCH1H1R5B	CHIP C 1.5PF B	C2,C5,C6	C134			CK73GB1H103K	CHIP C 0.010UF K	
C59, 60			CC73HCH1H010B	CHIP C 1.0PF B	C,C5,C6	C135			CK73GB1C104K	CHIP C 0.10UF K	
C60			CC73HCH1H010B	CHIP C 1.0PF B	C2	C136			CK73GB1A105K	CHIP C 1.0UF K	
C61			CC73HCH1H030B	CHIP C 3.0PF B	C	C138			CK73GB1H102K	CHIP C 1000PF K	
C61			CC73HCH1H040B	CHIP C 4.0PF B	C2	C140			CC73GCH1H101J	CHIP C 100PF J	
C61			CC73HCH1H050B	CHIP C 5.0PF B	C5,C6	C145			CC73GCH1H180J	CHIP C 18PF J	C
C62			CC73HCH1H020B	CHIP C 2.0PF B	C						
C62			CC73HCH1H030B	CHIP C 3.0PF B	C2,C5,C6	C145			CC73GCH1H240J	CHIP C 24PF J	C5
C63			CC73HCH1H101J	CHIP C 100PF J		C145			CC73GCH1H270J	CHIP C 27PF J	C6
C64			CC73HCH1H030B	CHIP C 3.0PF B	C5,C6	C145			CC73GCH1H300J	CHIP C 30PF J	C2
C64			CC73HCH1H040B	CHIP C 4.0PF B	C2	C146			CK73GB1H102K	CHIP C 1000PF K	
						C148			CK73GB1H102K	CHIP C 1000PF K	
C64			CC73HCH1H050B	CHIP C 5.0PF B	C						
C65			CC73HCH1H040B	CHIP C 4.0PF B	C6	C149			CC73GCH1H070B	CHIP C 7.0PF B	C,C2
C65-67			CC73HCH1H040B	CHIP C 4.0PF B	C5	C149			CC73GCH1H100C	CHIP C 10PF C	C6
C65, 66			CC73HCH1H050B	CHIP C 5.0PF B	C2	C151			CC73GCH1H070B	CHIP C 7.0PF B	C2
C65, 66			CC73HCH1H070B	CHIP C 7.0PF B	C	C152			CC73GCH1H200J	CHIP C 20PF J	C
C66			CC73HCH1H050B	CHIP C 5.0PF B	C6	C152			CC73GCH1H270J	CHIP C 27PF J	C5,C6
C67			CC73HCH1H040B	CHIP C 4.0PF B	C2,C6						
C67			CC73HCH1H050B	CHIP C 5.0PF B	C	C152			CC73GCH1H300J	CHIP C 30PF J	C2
C68-70			CK73HB1H471K	CHIP C 470PF K		C154			CK73GB1H471K	CHIP C 470PF K	
C71, 72			CK73HB1A104K	CHIP C 0.10UF K		C156			CC73GCH1H030B	CHIP C 3.0PF B	C2
C73, 74			CC73HCH1H0R5B	CHIP C 0.5PF B		C156			CC73GCH1H040B	CHIP C 4.0PF B	C
C75, 76			CK73HB1H102K	CHIP C 1000PF K		C156			CC73GCH1H060B	CHIP C 6.0PF B	C5
C77			CK73HB1H471K	CHIP C 470PF K		C156			CC73GCH1H090B	CHIP C 9.0PF B	C6
C78			CC73HCH1H330J	CHIP C 33PF J		C157			CC73GCH1H010B	CHIP C 1.0PF B	C
C79			C92-0713-05	CHIP-TAN 10UF 6.3WV		C157			CC73GCH1H040B	CHIP C 4.0PF B	C2
C80			CK73HB1H471K	CHIP C 470PF K		C157			CC73GCH1H2R5B	CHIP C 2.5PF B	C5
C83			CC73HCH1H050B	CHIP C 5.0PF B	C6	C157			CC73GCH1H3R5B	CHIP C 3.5PF B	C6
C83			CC73HCH1H150J	CHIP C 15PF J	C,C2,C5	C158			CC73GCH1H101J	CHIP C 100PF J	C,C2
C84-86			CK73HB1H102K	CHIP C 1000PF K		C158			CK73GB1H102K	CHIP C 1000PF K	C5,C6
C87			CC73HCH1H100D	CHIP C 10PF D		C159			CC73GCH1H010B	CHIP C 1.0PF B	C5,C6
C90			CK73HB1H102K	CHIP C 1000PF K		C159			CC73GCH1H020C	CHIP C 2.0PF C	C,C2
C100			CK73HB1H471K	CHIP C 470PF K		C160			CC73GCH1H020B	CHIP C 2.0PF B	C,C2
C101			CK73GB1H471K	CHIP C 470PF K		C160			CC73GCH1H1R5B	CHIP C 1.5PF B	C5,C6
C102			CC73GCH1H120J	CHIP C 12PF J		C161			CC73GCH1H050B	CHIP C 5.0PF B	C,C2
C106			CK73HB1H471K	CHIP C 470PF K		C161			CC73GCH1H060B	CHIP C 6.0PF B	C5,C6
C107			CC73GCH1H060B	CHIP C 6.0PF B	C	C163			CC73GCH1H030B	CHIP C 3.0PF B	
C107			CC73GCH1H070D	CHIP C 7.0PF D	C2	C164			CC73GCH1H050B	CHIP C 5.0PF B	C,C2
C107			CC73GCH1H080B	CHIP C 8.0PF B	C5,C6	C164			CC73GCH1H060B	CHIP C 6.0PF B	C5,C6
C108			CK73HB1H471K	CHIP C 470PF K		C166			CC73GCH1HR75B	CHIP C 0.75PF B	C,C2
C110,111			CK73GB1H471K	CHIP C 470PF K		C166			CC73GCH1H030B	CHIP C 3.0PF B	C5,C6
C112			CC73GCH1H070D	CHIP C 7.0PF D		C169			CC73GCH1H060B	CHIP C 6.0PF B	C,C6
C113			CK73GB1C104K	CHIP C 0.10UF K		C169			CC73GCH1H100C	CHIP C 10PF C	C2

PARTS LIST / 零件表

TX-RX UNIT (X57-6890-XX)

Ref. No.	Address	New parts	Parts No.	Description	Destination	Ref. No.	Address	New parts	Parts No.	Description	Destination
C169			CC73GCH1H4R5B	CHIP C 4.5PF B	C5	C262,263			CK73HB1H471K	CHIP C 470PF K	
C190			CK73GB1A105K	CHIP C 1.0UF K		C265			CK73HB1H471K	CHIP C 470PF K	
C191			CK73GB1H103K	CHIP C 0.010UF K		C266			CK73GB1H471K	CHIP C 470PF K	
C201			CK73GB1A224K	CHIP C 0.22UF K		C267			CC73GCH1H050B	CHIP C 5.0PF B	C5
C206			CK73HB1H102K	CHIP C 1000PF K		C267			CC73GCH1H060B	CHIP C 6.0PF B	C2,C6
C207			CK73HB1H182K	CHIP C 1800PF K		C267			CC73GCH1H2R5B	CHIP C 2.5PF B	C
C208			CK73HB1H471K	CHIP C 470PF K		C268			CC73GCH1H220J	CHIP C 22PF J	C,C2
C209			C92-0713-05	CHIP-TAN 10UF 6.3WV		C268			CC73GCH1H270J	CHIP C 27PF J	C5,C6
C210			CK73HB1H471K	CHIP C 470PF K		C269			CC73GCH1H020B	CHIP C 2.0PF B	C,C2,C6
C211			CK73HB1C103K	CHIP C 0.010UF K		C269			CC73GCH1H1R5B	CHIP C 1.5PF B	C5
C213			CK73HB1A104K	CHIP C 0.10UF K		C270,271			CK73HB1H471K	CHIP C 470PF K	
C214			CC73HCH1H680J	CHIP C 68PF J		C272			CC73GCH1H020B	CHIP C 2.0PF B	
C215			CK73HB1H102K	CHIP C 1000PF K		C273			CC73GCH1H220J	CHIP C 22PF J	C,C2
C216			CK73GB1C104K	CHIP C 0.10UF K		C273			CC73GCH1H270J	CHIP C 27PF J	C5,C6
C217			CK73HB1A104K	CHIP C 0.10UF K		C274			CC73GCH1H040B	CHIP C 4.0PF B	C2,C5,C6
C218			CK73GB1C104K	CHIP C 0.10UF K		C275			CC73GCH1H020B	CHIP C 2.0PF B	C2
C219			CC73HCH1H330J	CHIP C 33PF J		C275			CC73GCH1H030B	CHIP C 3.0PF B	C6
C220			CK73HB1H102K	CHIP C 1000PF K		C275			CC73GCH1H1R5B	CHIP C 1.5PF B	C5
C221			CK73GB1C104K	CHIP C 0.10UF K		C275			CC73GCH1H2R5B	CHIP C 2.5PF B	C
C222			CK73HB1H102K	CHIP C 1000PF K		C276			CC73GCH1H040B	CHIP C 4.0PF B	C,C2,C5
C224,225			CK73HB1C103K	CHIP C 0.010UF K		C276			CC73GCH1H4R5B	CHIP C 4.5PF B	C6
C228			CC73GCH1H100C	CHIP C 10PF C		C290			CC73GCH1H020B	CHIP C 2.0PF B	C,C2
C230			CK73HB1C103K	CHIP C 0.010UF K		C290			CC73GCH1H050B	CHIP C 5.0PF B	C5,C6
C231			CK73GB1H103K	CHIP C 0.010UF K		C291			CC73GCH1H060B	CHIP C 6.0PF B	C,C2
C232			CK73HB1C103K	CHIP C 0.010UF K		C291			CC73GCH1H100C	CHIP C 10PF C	C5,C6
C233			CC73GCH1H060B	CHIP C 6.0PF B	C,C2	C292			CK73HB1H102K	CHIP C 1000PF K	C5,C6
C233			CC73GCH1H100C	CHIP C 10PF C	C5,C6	C292			CK73HB1H471K	CHIP C 470PF K	C,C2
C234			CK73HB1H102K	CHIP C 1000PF K		C293			CC73GCH1H040B	CHIP C 4.0PF B	C5,C6
C236			CC73GCH1H180J	CHIP C 18PF J		C301			CK73HB1H392K	CHIP C 3900PF K	
C237			CK73HB1H102K	CHIP C 1000PF K		C302			CK73HB1H271K	CHIP C 270PF K	
C238			CK73GB1C104K	CHIP C 0.10UF K		C304			CK73GB1A224K	CHIP C 0.22UF K	
C239			CK73GB1H102K	CHIP C 1000PF K		C306			C92-0714-05	CHIP-TAN 4.7UF 6.3WV	
C240			CC73GCH1H010B	CHIP C 1.0PF B	C2,C5,C6	C307,308			CK73HB1A104K	CHIP C 0.10UF K	
C240			CC73GCH1H3R5B	CHIP C 3.5PF B	C	C309			CC73GCH1H820J	CHIP C 82PF J	
C241			CK73GB1H471K	CHIP C 470PF K		C310			CK73HB1A683K	CHIP C 0.068UF K	
C244			CC73GCH1H2R5B	CHIP C 2.5PF B	C	C311			CK73GB1A105K	CHIP C 1.0UF K	
C245			CC73GCH1H220J	CHIP C 22PF J	C	C312			CC73GCH1H120J	CHIP C 12PF J	
C246			CC73GCH1H020B	CHIP C 2.0PF B	C	C313			CC73GCH1H121J	CHIP C 120PF J	
C247			CK73HB1H471K	CHIP C 470PF K	C,C5,C6	C314			CK73HB1A104K	CHIP C 0.10UF K	
C248			CC73GCH1H020B	CHIP C 2.0PF B	C	C315			CK73GB1A105K	CHIP C 1.0UF K	
C249			CC73GCH1H030B	CHIP C 3.0PF B	C5	C316			CK73GB1C104K	CHIP C 0.10UF K	
C249			CC73GCH1H050B	CHIP C 5.0PF B	C2	C317			CK73HB1A104K	CHIP C 0.10UF K	
C249			CC73GCH1H3R5B	CHIP C 3.5PF B	C6	C318			C92-0714-05	CHIP-TAN 4.7UF 6.3WV	
C249			CC73GCH1H4R5B	CHIP C 4.5PF B	C	C319			CC73GCH1H271J	CHIP C 270PF J	
C250			CC73GCH1H220J	CHIP C 22PF J	C,C2	C320			CK73HB1C103K	CHIP C 0.010UF K	
C250			CC73GCH1H270J	CHIP C 27PF J	C5,C6	C321			CK73GB1A105K	CHIP C 1.0UF K	
C251			CK73HB1H471K	CHIP C 470PF K		C322			CK73HB1C153K	CHIP C 0.015UF K	
C252			CC73GCH1H010B	CHIP C 1.0PF B	C,C5,C6	C323			CC73GCH1H820J	CHIP C 82PF J	
C252			CC73GCH1H1R5B	CHIP C 1.5PF B	C2	C324			CC73HCH1H820J	CHIP C 82PF J	
C253			CC73GCH1H020B	CHIP C 2.0PF B	C2	C325			CK73HB1A104K	CHIP C 0.10UF K	
C253			CC73GCH1H1R5B	CHIP C 1.5PF B	C,C5,C6	C326			CK73HB1H102K	CHIP C 1000PF K	
C254			CK73HB1H471K	CHIP C 470PF K		C327			CC73HCH1H101J	CHIP C 100PF J	
C255			CC73GCH1H220J	CHIP C 22PF J	C,C2	C328			CK73HB1H391K	CHIP C 390PF K	
C255			CC73GCH1H270J	CHIP C 27PF J	C5,C6	C329,330			CK73GB1A105K	CHIP C 1.0UF K	
C256			C92-0714-05	CHIP-TAN 4.7UF 6.3WV		C331			CK73HB1A104K	CHIP C 0.10UF K	
C257			CC73GCH1H040B	CHIP C 4.0PF B	C	C332			CK73HB1H471K	CHIP C 470PF K	
C257			CC73GCH1H060B	CHIP C 6.0PF B	C5,C6	C333,334			CK73GB1C104K	CHIP C 0.10UF K	
C257			CC73GCH1H070B	CHIP C 7.0PF B	C2	C335			CC73GCH1H221J	CHIP C 220PF J	
C258			CK73HB1H471K	CHIP C 470PF K		C336			CK73FB1C474K	CHIP C 0.47UF J	
C259			CK73GB1H471K	CHIP C 470PF K		C338			CC73GCH1H101J	CHIP C 100PF J	

PARTS LIST / 零件表

TX-RX UNIT (X57-6890-XX)

Ref. No.	Address	New parts	Parts No.	Description	Destination	Ref. No.	Address	New parts	Parts No.	Description	Destination
C339			C92-0560-05	CHIP-TAN 10UF 6.3WV		L18, 19			L41-2285-03	SMALL FIXED INDUCTOR	
C340			CK73GB1C104K	CHIP C 0.10UF K		L20, 21			L40-3391-86	SMALL FIXED INDUCTOR(3.3UH)	
C341			CK73GB1C473K	CHIP C 0.047UF K		L22			L92-0138-05	FERRITE CHIP	
C342			C92-0560-05	CHIP-TAN 10UF 6.3WV		L23			L40-2275-92	SMALL FIXED INDUCTOR(22NH)	
C343			CK73GB1C473J	CHIP C 0.047UF J		L24			L92-0141-05	FERRITE CHIP	
C344			CC73GCH1H221J	CHIP C 220PF J		L25			L40-2275-92	SMALL FIXED INDUCTOR(22NH)	
C345			C92-0665-05	TANTAL 100UF 6.3WV		L100			L40-2775-92	SMALL FIXED INDUCTOR(27NH)	C5,C6
C346			CK73GB1H102K	CHIP C 1000PF K		L100			L40-3375-92	SMALL FIXED INDUCTOR(33NH)	C2
C348			CK73HB1H471K	CHIP C 470PF K		L100,101			L40-1575-92	SMALL FIXED INDUCTOR(15NH)	C
C351,352			CK73HB1C103K	CHIP C 0.010UF K		L101			L40-2275-92	SMALL FIXED INDUCTOR(22NH)	C2,C5,C6
C354			CK73HB1A104K	CHIP C 0.10UF K		L102			L92-0138-05	FERRITE CHIP	
C370			CK73HB1A104K	CHIP C 0.10UF K		L103,104			L40-8265-92	SMALL FIXED INDUCTOR(8.2NH)	
C401			CC73GCH1H471J	CHIP C 470PF J		L105			L40-1575-54	SMALL FIXED INDUCTOR(15NH)	
C402			CK73HB1H102K	CHIP C 1000PF K		L106			L92-0149-05	FERRITE CHIP	
C403			CK73GB1C104K	CHIP C 0.10UF K		L107			L40-1263-92	SMALL FIXED INDUCTOR(1.2NH)	C
C405			CC73GCH1H101J	CHIP C 100PF J		L109			L92-0149-05	FERRITE CHIP	
C407			CK73HB1H102K	CHIP C 1000PF K		L110			L40-2285-54	SMALL FIXED INDUCTOR(220NH)	
C409,410			CK73GB1A105K	CHIP C 1.0UF K		L111			L40-1092-81	SMALL FIXED INDUCTOR	
C411			CK73HB1H102K	CHIP C 1000PF K		L201			L40-1091-37	SMALL FIXED INDUCTOR(1.000UH)	
C415			CK73HB1H471K	CHIP C 470PF K		L202			L92-0138-05	FERRITE CHIP	
C417			CK73GB1A105K	CHIP C 1.0UF K		L203			L40-5685-85	SMALL FIXED INDUCTOR(0.56UH)	
C418,419			CK73HB1H102K	CHIP C 1000PF K		L204			L40-2785-92	SMALL FIXED INDUCTOR(270NH)	
C421			CK73GB1A105K	CHIP C 1.0UF K		L206			L40-3975-92	SMALL FIXED INDUCTOR(39NH)	C2
C426,427			CK73GB1A105K	CHIP C 1.0UF K		L206			L40-5675-92	SMALL FIXED INDUCTOR(56NH)	C5,C6
C428,429			CK73HB1H102K	CHIP C 1000PF K		L211,212			L41-8268-14	SMALL FIXED INDUCTOR	C
C430			CK73GB1H103K	CHIP C 0.010UF K		L212			L41-1278-14	SMALL FIXED INDUCTOR	C5,C6
C431			CK73HB1C103K	CHIP C 0.010UF K		L212			L41-8268-14	SMALL FIXED INDUCTOR	C2
C432			CC73HCH1H050B	CHIP C 5.0PF B		L214			L41-1278-14	SMALL FIXED INDUCTOR	C5,C6
C433,434			CC73HCH1H030B	CHIP C 3.0PF B		L214			L41-8268-14	SMALL FIXED INDUCTOR	C,C2
C435			CC73HCH1H050B	CHIP C 5.0PF B		L215			L41-2285-03	SMALL FIXED INDUCTOR	
C440			CC73GCH1H1R5B	CHIP C 1.5PF B		L220			L34-4602-05	AIR-CORE COIL	
C443			CK73GB1A474K	CHIP C 0.47UF K		L223			L34-4572-05	AIR-CORE COIL	C,C5,C6
C444			CC73GCH1H020B	CHIP C 2.0PF B	C2	L224			L34-4564-05	AIR-CORE COIL	
C444			CC73GCH1H100C	CHIP C 10PF C	C5	L225			L34-4564-05	AIR-CORE COIL	C,C2
C901,902			CK73GB1A105K	CHIP C 1.0UF K		L225			L34-4565-05	AIR-CORE COIL	C5,C6
TC1, 2			C05-0384-05	CERAMIC TRIMMER CAP(10PF)		L226			L34-4564-05	AIR-CORE COIL	
CN201			E23-1081-05	TERMINAL		L228,229			L41-1278-14	SMALL FIXED INDUCTOR	C5,C6
CN401			E40-6362-05	FLAT CABLE CONNECTOR		L228,229			L41-8268-14	SMALL FIXED INDUCTOR	C,C2
J301			E11-0457-05	PHONE JACK(2.5/3.5)		L230			L41-3978-03	SMALL FIXED INDUCTOR	C
F401			F53-0190-05	FUSE(2.5A)		L230			L41-5678-03	SMALL FIXED INDUCTOR	C2
60	2A		J30-1282-04	SPACER(MIC ELEMENT)		L230			L41-6878-03	SMALL FIXED INDUCTOR	C5
CD201			L79-1582-05	TUNING COIL		L230			L41-7278-03	SMALL FIXED INDUCTOR	C6
CF201			L72-0973-05	CERAMIC FILTER(450KHZ)		L250			L40-1575-92	SMALL FIXED INDUCTOR(15NH)	C5,C6
L1		2A	L40-4791-37	SMALL FIXED INDUCTOR(4.700UH)		L250			L40-1875-92	SMALL FIXED INDUCTOR(18NH)	C,C2
L3			L40-5681-86	SMALL FIXED INDUCTOR(0.56UH)		L290			L41-3078-17	SMALL FIXED INDUCTOR	C
L5			L40-5681-86	SMALL FIXED INDUCTOR(0.56UH)		L301			L92-0140-05	FERRITE CHIP	
L6, 7			L92-0138-05	FERRITE CHIP		L302			L92-0149-05	FERRITE CHIP	
L8, 9			L40-1875-92	SMALL FIXED INDUCTOR(18NH)		L401			L92-0149-05	FERRITE CHIP	
L10, 11			L40-1085-92	SMALL FIXED INDUCTOR(100NH)		L402-404			L92-0138-05	FERRITE CHIP	
L12			L92-0138-05	FERRITE CHIP		L410			L92-0138-05	FERRITE CHIP	
L13, 14			L40-1085-92	SMALL FIXED INDUCTOR(100NH)		L411			L92-0138-05	FERRITE CHIP	
L16			L40-2278-67	SMALL FIXED INDUCTOR(22NH)	C	L412			L40-1875-92	SMALL FIXED INDUCTOR(18NH)	
L16			L40-2778-67	SMALL FIXED INDUCTOR(27NH)	C2	X1			L34-4564-05	AIR-CORE COIL	C2
L16			L40-3978-67	SMALL FIXED INDUCTOR(39NH)	C5,C6	X2			L77-1931-05	TCXO(12.8MHZ)	
L17			L40-2778-67	SMALL FIXED INDUCTOR(27NH)	C	XF201			L78-1411-05	RESONATOR(7.37MHZ)	
L17			L40-3378-67	SMALL FIXED INDUCTOR(33NH)	C2				L71-0619-05	MCF(38.85MHZ)	
L17			L40-4778-67	SMALL FIXED INDUCTOR(47NH)	C5,C6	CP404			RK75HA1J473J	CHIP-COM 47K J 1/16W	
						CP405			RK75HA1J102J	CHIP-COM 1.0K J 1/16W	
						R1			RK73HB1J223J	CHIP R 22K J 1/16W	
						R2			RK73HB1J103J	CHIP R 10K J 1/16W	
						R3			RK73HB1J333J	CHIP R 33K J 1/16W	

PARTS LIST / 零件表

TX-RX UNIT (X57-6890-XX)

Ref. No.	Address	New parts	Parts No.	Description	Destination	Ref. No.	Address	New parts	Parts No.	Description	Destination
R4			RK73HB1J563J	CHIP R 56K J 1/16W		R137			R92-0670-05	CHIP R 0 OHM	
R5			RK73HB1J104J	CHIP R 100K J 1/16W		R138			RK73GB1J105J	CHIP R 1.0M J 1/16W	
R6			RK73HB1J823J	CHIP R 82K J 1/16W		R139			RK73GB1J473J	CHIP R 47K J 1/16W	
R7			RK73HB1J101J	CHIP R 100 J 1/16W		R140			RK73GB1J563J	CHIP R 56K J 1/16W	
R8 -11			R92-1368-05	CHIP R 0 OHM		R141			RK73GB1J104J	CHIP R 100K J 1/16W	
R12			RK73HB1J222J	CHIP R 2.2K J 1/16W		R142			R92-1252-05	CHIP R 0 OHM J 1/16W	
R13			R92-1252-05	CHIP R 0 OHM J 1/16W		R143			RK73GB1J104J	CHIP R 100K J 1/16W	
R14			RK73HB1J334J	CHIP R 330K J 1/16W		R145			R92-1252-05	CHIP R 0 OHM J 1/16W	
R15			RK73GB1J221J	CHIP R 220 J 1/16W		R147			R92-1252-05	CHIP R 0 OHM J 1/16W	
R16			RK73GB1J561J	CHIP R 560 J 1/16W		R190			RK73GB1J101J	CHIP R 100 J 1/16W	
R17			RK73HB1J101J	CHIP R 100 J 1/16W		R191,192			RK73GB1J271J	CHIP R 270 J 1/16W	
R18			RK73HB1J181J	CHIP R 180 J 1/16W		R193			RK73GB1J473J	CHIP R 47K J 1/16W	C2
R19			RK73GB1J122J	CHIP R 1.2K J 1/16W		R193,194			RK73GB1J473J	CHIP R 47K J 1/16W	C, C5, C6
R20			RK73HB1J100J	CHIP R 10 J 1/16W		R194			RK73GB1J223J	CHIP R 22K J 1/16W	C2
R21			RK73GB1J681J	CHIP R 680 J 1/16W		R203			RK73HB1J184J	CHIP R 180K J 1/16W	
R22			R92-1252-05	CHIP R 0 OHM J 1/16W		R206			RK73GB1J100J	CHIP R 10 J 1/16W	
R23			RK73GB1J103J	CHIP R 10K J 1/16W		R207			RK73HB1J472J	CHIP R 4.7K J 1/16W	
R25			RK73HB1J223J	CHIP R 22K J 1/16W		R208			RK73HB1J823J	CHIP R 82K J 1/16W	
R26			RK73HB1J103J	CHIP R 10K J 1/16W		R209			RK73HB1J272J	CHIP R 2.7K J 1/16W	
R27			RK73HB1J220J	CHIP R 22 J 1/16W		R210,211			RK73HB1J332J	CHIP R 3.3K J 1/16W	
R30			RK73HB1J273J	CHIP R 27K J 1/16W	C5, C6	R212			RK73HB1J823J	CHIP R 82K J 1/16W	
R30			RK73HB1J333J	CHIP R 33K J 1/16W	C, C2	R213			RK73HB1J392J	CHIP R 3.9K J 1/16W	
R31			RK73HB1J474J	CHIP R 470K J 1/16W		R215			RK73HB1J101J	CHIP R 100 J 1/16W	
R32			RK73HB1J102J	CHIP R 1.0K J 1/16W		R216			RK73HB1J124J	CHIP R 120K J 1/16W	
R33			RK73HB1J154J	CHIP R 150K J 1/16W		R217			RK73HB1J472J	CHIP R 4.7K J 1/16W	
R34			RK73HB1J474J	CHIP R 470K J 1/16W		R218			RK73HB1J561J	CHIP R 560 J 1/16W	
R35, 36			RK73HB1J274J	CHIP R 270K J 1/16W		R219			RK73GB1J561J	CHIP R 560 J 1/16W	
R37			RK73HB1J101J	CHIP R 100 J 1/16W		R226,227			RK73GB1J102J	CHIP R 1.0K J 1/16W	
R38			RK73HB1J181J	CHIP R 180 J 1/16W		R228			RK73GB1J151J	CHIP R 150 J 1/16W	
R39			RK73HB1J151J	CHIP R 150 J 1/16W	C2, C5, C6	R233			RK73HB1J104J	CHIP R 100K J 1/16W	
R39, 40			RK73HB1J151J	CHIP R 150 J 1/16W	C	R236			RK73HB1J563J	CHIP R 56K J 1/16W	
R40			RK73HB1J101J	CHIP R 100 J 1/16W	C2, C5, C6	R238			RK73HB1J104J	CHIP R 100K J 1/16W	
R41			RK73HB1J154J	CHIP R 150K J 1/16W		R239			RK73HB1J563J	CHIP R 56K J 1/16W	
R42			RK73HB1J103J	CHIP R 10K J 1/16W	C	R240			R92-1252-05	CHIP R 0 OHM J 1/16W	
R42			RK73HB1J472J	CHIP R 4.7K J 1/16W	C2, C5, C6	R241			RK73HB1J105J	CHIP R 1.0M J 1/16W	C, C5, C6
R43			RK73HB1J101J	CHIP R 100 J 1/16W		R243,244			RK73HB1J105J	CHIP R 1.0M J 1/16W	
R46			RK73HB1J103J	CHIP R 10K J 1/16W		R248			RK73GB1J221J	CHIP R 220 J 1/16W	
R47			RK73HB1J220J	CHIP R 22 J 1/16W		R249			RK73GB1J220J	CHIP R 22 J 1/16W	
R48			RK73HB1J331J	CHIP R 330 J 1/16W		R251			RK73HB1J104J	CHIP R 100K J 1/16W	
R49			RK73HB1J222J	CHIP R 2.2K J 1/16W		R253			RK73HB1J104J	CHIP R 100K J 1/16W	
R50			RK73HB1J472J	CHIP R 4.7K J 1/16W		R254			RK73HB1J683J	CHIP R 68K J 1/16W	
R100			RK73HB1J472J	CHIP R 4.7K J 1/16W		R255			R92-1252-05	CHIP R 0 OHM J 1/16W	
R103			RK73GB1J103J	CHIP R 10K J 1/16W	C2	R256,257			RK73HB1J105J	CHIP R 1.0M J 1/16W	
R103			RK73GB1J473J	CHIP R 47K J 1/16W	C, C5, C6	R258			R92-0670-05	CHIP R 0 OHM	
R105			RK73GB1J331J	CHIP R 330 J 1/16W		R301			RK73HB1J103J	CHIP R 10K J 1/16W	
R106			RK73GB1J121J	CHIP R 120 J 1/16W	C2	R304			RK73HB1J273J	CHIP R 27K J 1/16W	
R106			RK73GB1J220J	CHIP R 22 J 1/16W	C, C5, C6	R305			RK73HB1J104J	CHIP R 100K J 1/16W	
R107			RK73HB1J101J	CHIP R 100 J 1/16W		R306			RK73HB1J102J	CHIP R 1.0K J 1/16W	
R110			RK73GB1J331J	CHIP R 330 J 1/16W		R307,308			R92-1368-05	CHIP R 0 OHM	
R111,112			R92-1252-05	CHIP R 0 OHM J 1/16W		R310			RK73GB1J394J	CHIP R 390K J 1/16W	
R114			RK73GB1J473J	CHIP R 47K J 1/16W		R311			RK73HB1J123J	CHIP R 12K J 1/16W	
R115			RK73GB1J103J	CHIP R 10K J 1/16W		R312			RK73GB1J334J	CHIP R 330K J 1/16W	
R116			RK73GB1J220J	CHIP R 22 J 1/16W		R313			RK73GB1J104J	CHIP R 100K J 1/16W	
R120			R92-1252-05	CHIP R 0 OHM J 1/16W	C2, C5, C6	R314			RK73GB1J103J	CHIP R 10K J 1/16W	
R121			RK73GB1J220J	CHIP R 22 J 1/16W		R315			RK73GB1J334J	CHIP R 330K J 1/16W	
R123			R92-0670-05	CHIP R 0 OHM		R316			RK73GB1J124J	CHIP R 120K J 1/16W	
R124			RK73GB1J473J	CHIP R 47K J 1/16W		R317			RK73GB1J474J	CHIP R 470K J 1/16W	
R126			RK73GB1J222J	CHIP R 2.2K J 1/16W		R318			RK73GB1J122J	CHIP R 1.2K J 1/16W	
R127-129			RK73EB2ER39K	CHIP R 0.39 K 1/4W		R319			RK73HB1J563J	CHIP R 56K J 1/16W	
R130-135			RK73GH1J154D	CHIP R 150K D 1/16W		R320			RK73HB1J332J	CHIP R 3.3K J 1/16W	

PARTS LIST / 零件表

TX-RX UNIT (X57-6890-XX)

Ref. No.	Address	New parts	Parts No.	Description	Destination	Ref. No.	Address	New parts	Parts No.	Description	Destination
R321			RK73HB1J224J	CHIP R 220K J 1/16W		D10			1SV278	VARIABLE CAPACITANCE DIODE	
R322			RK73HB1J184J	CHIP R 180K J 1/16W		D11			MA2S111	DIODE	
R323			RK73HB1J563J	CHIP R 56K J 1/16W		D101			HSC277	DIODE	
R324,325			RK73GB1J104J	CHIP R 100K J 1/16W		D102			HZU5CLL	ZENER DIODE	
R326			R92-1252-05	CHIP R 0 OHM J 1/16W		D103,104			HVC131	DIODE	
R327			RK73GB1J184J	CHIP R 180K J 1/16W		D106			HVC131	DIODE	
R328			RK73GB1J103J	CHIP R 10K J 1/16W		D122			HVC131	DIODE	
R329			RK73GB1J823J	CHIP R 82K J 1/16W		D202			HSC277	DIODE	
R330			RK73HB1J332J	CHIP R 3.3K J 1/16W		D203-206			HVC355B	VARIABLE CAPACITANCE DIODE	
R331			RK73GB1J154J	CHIP R 150K J 1/16W		D210			HVC355B	VARIABLE CAPACITANCE DIODE	C,C5,C6
R332			RK73GB1J153J	CHIP R 15K J 1/16W		D301,302			RB706F-40	DIODE	
R334			RK73GB1J473J	CHIP R 47K J 1/16W		D303			DAN222	DIODE	
R335			RK73GB1J222J	CHIP R 2.2K J 1/16W		D401			RB521S-30	DIODE	
R336			RK73GB1J102J	CHIP R 1.0K J 1/16W		D402			1SR154-400	DIODE	
R337			RK73GB1J151J	CHIP R 150 J 1/16W		D405			KDZ3.3V	ZENER DIODE	C5,C6
R338			RK73GB1J222J	CHIP R 2.2K J 1/16W		IC1			MB15A02	MOS IC	
R339			RK73GB1J471J	CHIP R 470 J 1/16W		IC101			TA75W01FU	MOS IC	
R340			RK73GB1J182J	CHIP R 1.8K J 1/16W		IC201			TA31136FN	MOS IC	
R341			RK73GB1J103J	CHIP R 10K J 1/16W		IC301			AQUA-L	MOS IC	
R342			RK73GB1J101J	CHIP R 100 J 1/16W		IC302			TA7368F	MOS IC	
R343			RK73GB1J474J	CHIP R 470K J 1/16W		IC401,402			XC6204B502MR	MOS IC	
R344			RK73GB1J102J	CHIP R 1.0K J 1/16W		IC403			BD4840FVE	MOS IC	
R345,346			RK73GB1J101J	CHIP R 100 J 1/16W		IC404			BD4845FVE	MOS IC	
R347			RK73GB1J104J	CHIP R 100K J 1/16W		IC405			30622MAA-B89GP	MPU	
R348			RK73GB1J563J	CHIP R 56K J 1/16W		IC406			BR24L08F-W	ROM IC	
R349			RK73GB1J333J	CHIP R 33K J 1/16W		Q1			KTC4082	TRANSISTOR	
R350			R92-1368-05	CHIP R 0 OHM		Q2			2SC5108(Y)	TRANSISTOR	
R354,355			RK73HB1J103J	CHIP R 10K J 1/16W		Q3, 4			2SK508NV(K52)	FET	
R357			R92-1368-05	CHIP R 0 OHM		Q5			DTA143TE	DIGITAL TRANSISTOR	
R360			R92-1368-05	CHIP R 0 OHM		Q6			2SC5108(Y)	TRANSISTOR	
R403			RK73GB1J101J	CHIP R 100 J 1/16W		Q7			DTA143TE	DIGITAL TRANSISTOR	
R404			RK73HB1J474D	CHIP R 470K D 1/16W		Q8			2SC4617(S)	TRANSISTOR	
R405			RK73GB1J334J	CHIP R 330K J 1/16W		Q9			2SC4619(P,Q)	TRANSISTOR	
R406			RK73HB1J474D	CHIP R 470K D 1/16W		Q100			2SC4619(P,Q)	TRANSISTOR	
R407			RK73HB1J334J	CHIP R 330K J 1/16W		Q101			2SK3077	FET	
R408-412			RK73HB1J473J	CHIP R 47K J 1/16W		Q102			2SK2596	FET	
R413,414			RK73GB1J331J	CHIP R 330 J 1/16W		Q103			2SK3476	FET	
R415,416			RK73GB1J473J	CHIP R 47K J 1/16W		Q104			DTC114EE	DIGITAL TRANSISTOR	
R417-420			RK73HB1J473J	CHIP R 47K J 1/16W		Q105			2SK879(Y)	FET	
R421,422			RK73HB1J102J	CHIP R 1.0K J 1/16W		Q107			DTC114EE	DIGITAL TRANSISTOR	
R423			R92-1368-05	CHIP R 0 OHM		Q108			2SK1824	FET	
R424,425			RK73HB1J473J	CHIP R 47K J 1/16W		Q109			DTA144EE	DIGITAL TRANSISTOR	
R426			R92-1368-05	CHIP R 0 OHM		Q202			DTA144EE	DIGITAL TRANSISTOR	
R435			RK73HB1J473J	CHIP R 47K J 1/16W		Q203			2SC4649(N,P)	TRANSISTOR	
R436			R92-1252-05	CHIP R 0 OHM J 1/16W		Q204,205			3SK318	FET	
R437,438			RK73HB1J473J	CHIP R 47K J 1/16W		Q301			DTA114EE	DIGITAL TRANSISTOR	
R445,446			R92-1252-05	CHIP R 0 OHM J 1/16W		Q302			2SC4919	TRANSISTOR	
R447			RK73HB1J123J	CHIP R 12K J 1/16W		Q303			DTC144EE	DIGITAL TRANSISTOR	
R449,450			R92-1252-05	CHIP R 0 OHM J 1/16W	C2,C5,C6	Q304			2SA1362(GR)	TRANSISTOR	
R452			RK73HB1J103J	CHIP R 10K J 1/16W		Q305			DTC144EE	DIGITAL TRANSISTOR	
R453			RK73HB1J223J	CHIP R 22K J 1/16W		Q306			CPH3413	FET	
R901,902			RK73GB1J472J	CHIP R 4.7K J 1/16W		Q316			CPH3413	FET	
VR1			R12-7491-05	TRIMMING POT.(68K)		Q401,402			DTC114EE	DIGITAL TRANSISTOR	
S401-403			S70-0414-05	TACT SWITCH		Q403,404			CPH3317	FET	
MIC301	2A		T91-0543-05	MIC ELEMENT		Q405			DTA123JE	DIGITAL TRANSISTOR	
D1			MA2S111	DIODE		Q407,408			2SK1830	FET	
D2 -9			HVC376B	VARIABLE CAPACITANCE DIODE		Q901			2SK1824	FET	
						TH101			157-104-65001	THERMISTOR	
						TH203			157-104-65001	THERMISTOR	

EXPLODED VIEW / 部件分解图

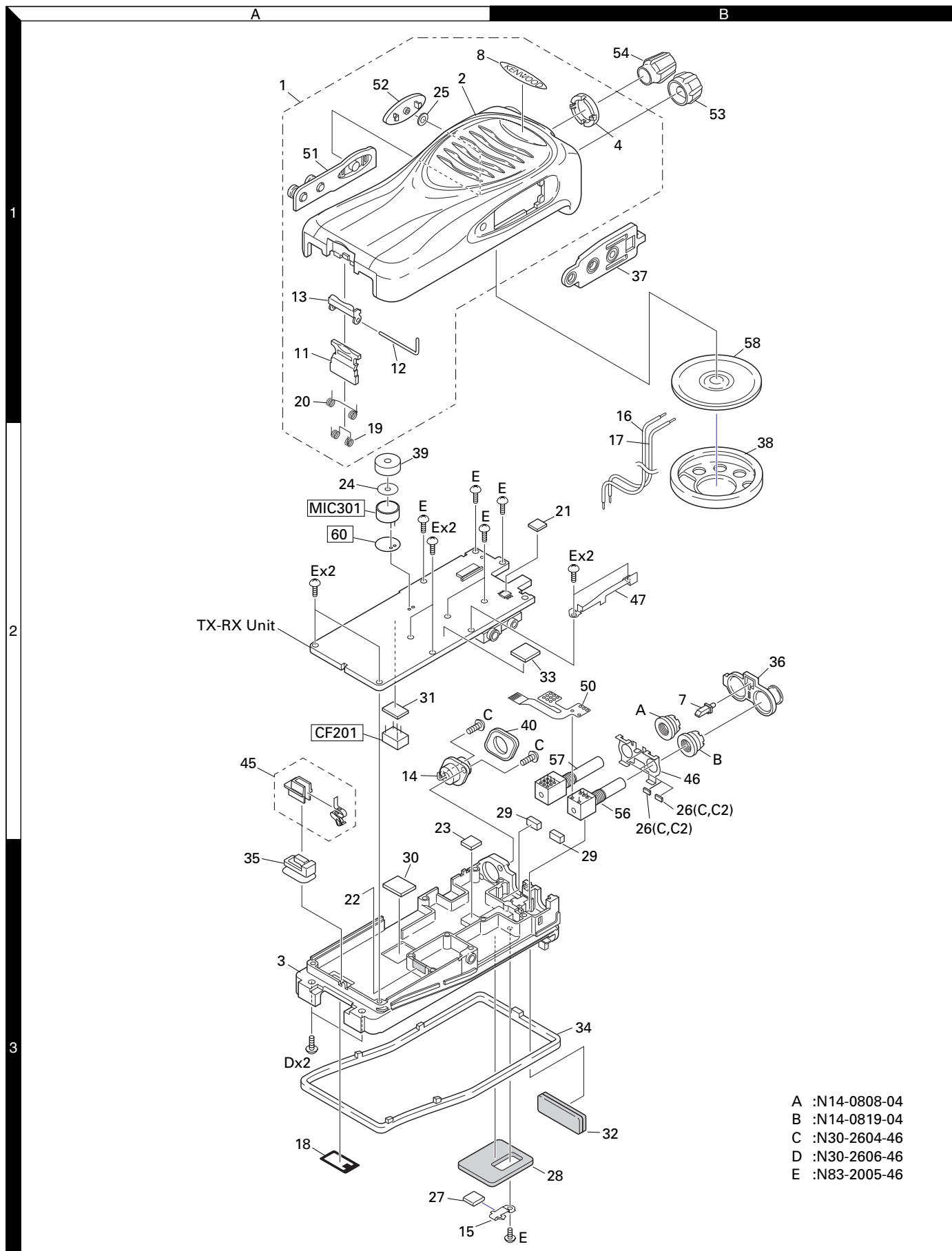

PACKING / 包装

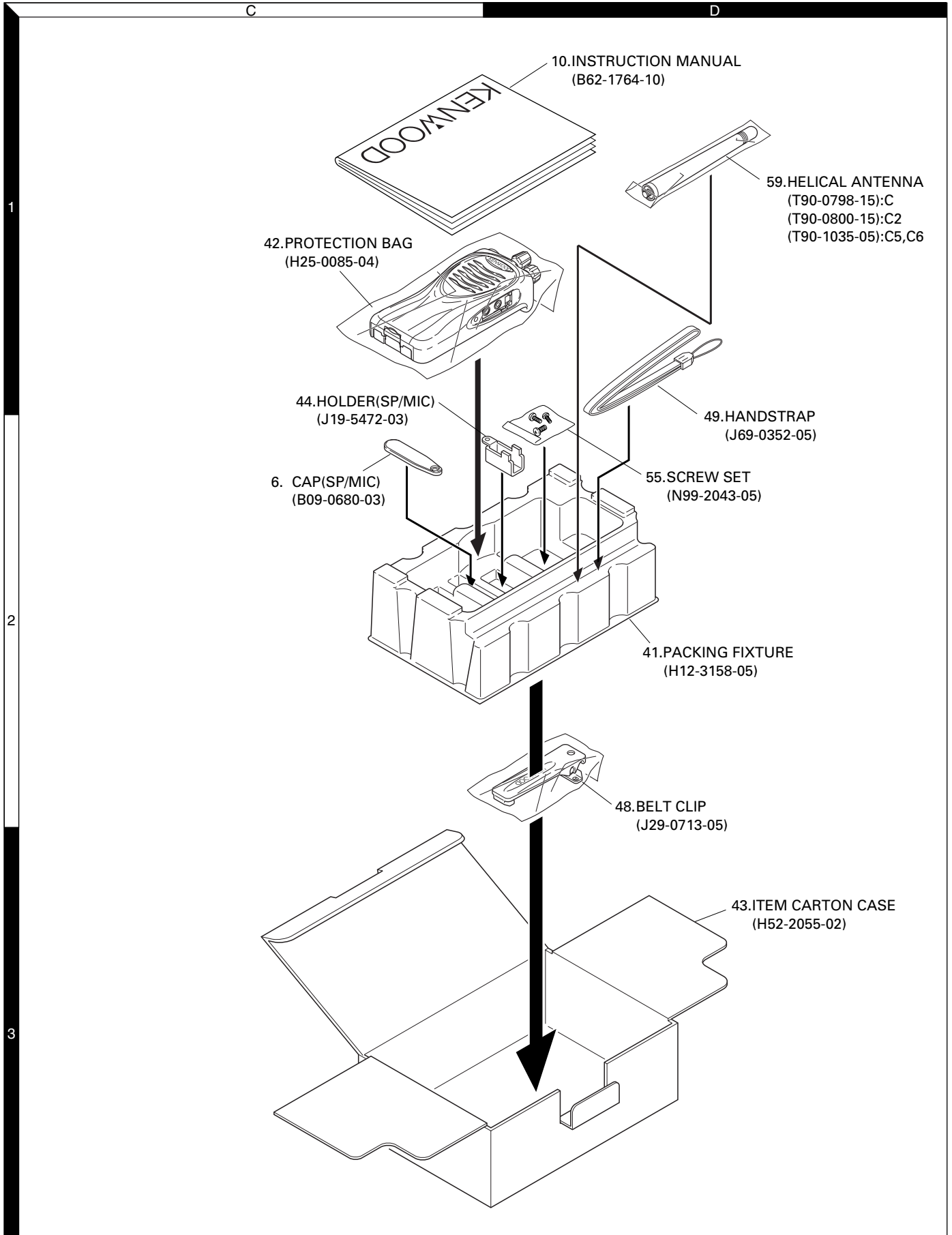

ADJUSTMENT / 调整

Test Equipment Required for Alignment

Test Equipment	Major Specifications	
1. Standard Signal Generator (SSG)	Frequency Range Modulation Output	370 to 390MHz (C5) 350 to 370MHz (C6) Frequency modulation and external modulation -127dBm/0.1 μ V to greater than -47dBm/1mV
2. Power Meter	Input Impedance Operation Frequency Measurement Range	50 Ω 370 to 390MHz (C5) 350 to 370MHz (C6) Vicinity of 10W
3. Deviation Meter	Frequency Range	370 to 390MHz (C5) 350 to 370MHz (C6)
4. Digital Volt Meter (DVM)	Measuring Range Input Impedance	10mV to 10V DC High input impedance for minimum circuit loading
5. Oscilloscope		DC through 30MHz
6. High Sensitivity Frequency Counter	Frequency Range Frequency Stability	10Hz to 1000MHz 0.2ppm or less
7. Ammeter		5A
8. AF Volt Meter (AF VTVM)	Frequency Range Voltage Range	50Hz to 10kHz 1mV to 10V
9. Audio Generator (AG)	Frequency Range Output	50Hz to 5kHz or more 0 to 1V
10. Distortion Meter	Capability Input Level	3% or less at 1kHz 50mV to 10Vrms
11. Spectrum Analyzer	Measuring Range	DC to 1GHz or more
12. Tracking Generator	Center frequency Output Voltage	50kHz to 600MHz 100mV or more
13. 8 Ω Dummy Load		Approx. 8 Ω , 3W
14. Regulated Power Supply		5V to 10V, approx. 3A Useful if ammeter equipped

所需的用于调整的测试设备

测试设备	主要特性	
1. 标准信号发生器 (SSG)	频率范围 调制 输出	370 到 390MHz (C5) 350 到 370MHz (C6) 调频和外部调制 -127dBm/0.1 μ V 到大于 -47dBm/1mV
2. 功率计	输入阻抗 操作频率 测量范围	50 Ω 370 到 390MHz (C5) 350 到 370MHz (C6) 10W 左右
3. 偏差仪	频率范围	370 到 390MHz (C5) 350 到 370MHz (C6)
4. 数字电压表 (DVM)	测量范围 输入阻抗	直流 10mV 到 10V 为最小电路负载高输入阻抗
5. 示波器		直流到 30MHz
6. 高灵敏度频率计数器	频率范围 频率稳定性	10Hz 到 1000MHz 0.2ppm 或更低
7. 电流表		5A
8. 音频电压表 (AF VTVM)	频率范围 电压范围	50Hz 到 10kHz 1mV 到 10V
9. 音频发生器 (AG)	频率范围 输出	50Hz 到 5kHz 或更高 0 到 1V
10. 失真测试仪	容量 输入电平	1kHz 时 3% 或更低 50mV 到 10Vrms
11. 频谱分析仪	测量范围	直流到 1GHz 或更高
12. 轨迹发生器	中心频率 输出电压	50kHz 到 600MHz 100mV 或更高
13. 8 Ω 假负载		大约 8 Ω , 3W
14. 可调电源		5V 到 10V, 大约 3A 配备了电流表时有用

ADJUSTMENT / 调整

■ The following parts are required for adjustment

1. Antenna connector adapter

The antenna connector of this transceiver uses an SMA terminal.

Use an antenna connector adapter [SMA(f) – BNC(f) or SMA(f) – N(f)] for adjustment. (The adapter is not provided as an option, so buy a commercially-available one.)

2. Repair Jig (Chassis)

Use jig (part No.: A10-4086-03) for repairing the TK-3207. Place the TX-RX unit on the jig and fit it with screws.

The jig facilitates the voltage check and protects the final amplifier FET when the voltage on the flow side of the TX-RX unit is checked during repairs.

3. Battery Jig (W05-1011-00)

Connect the power cable properly between the battery jig installed in the transceiver and the power supply, and be sure output voltage and the power supply polarity prior to switching the power supply ON, otherwise over voltage and reverse connection may damage the transceiver, or the power supply or both.

Note: When using the battery jig, you must measure the voltage at the terminals of the battery jig. Otherwise, a slight voltage drop may occur within the power cable, between the power supply and the battery jig, especially while the transceiver transmits.

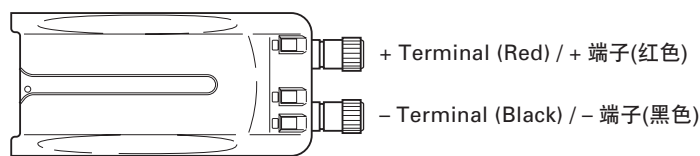

■ 下面是调整时所需的部件

1. 天线接口转换头

此对讲机的天线接口使用 SMA 终端。

使用天线接口转换头 [SMA(f)-BNC(f) 或 SMA(f)-N(f)] 进行调整。(转换头不作为可选件提供, 因此请购买商用转换头。)

2. 维修机架 (机壳)

使用机壳 (A10-4086-03) 维修 TK-3207。将 TX-RX 单元放置在机壳上, 并且拧上螺钉。

在维修过程中, 需要在 TX-RX 单元的电路板上检测电压时, 机壳可以方便地进行电压检测, 并且保护模块。

3. 电池夹具 (W05-1011-00)

在对讲机的电池夹具和电源之间连接适当的电源电缆, 确认了输出电压之后接通电源开关, 电压过高或极性颠倒都有可能损坏对讲机。

注: 当使用电池夹具时, 你必须测定电池夹具的终端电压。因为, 电源和电池夹具之间会有一些的电压下降, 尤其在对讲机发射的时候。

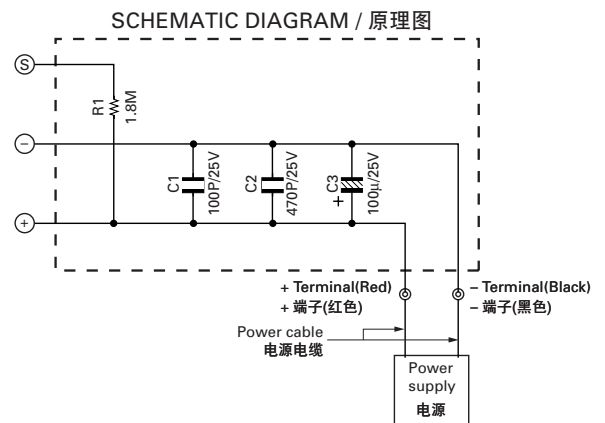

ADJUSTMENT / 调整

Adjustment points TX-RX unit (X57-689) Component side view

TX-RX 单元(X57-689) 调整点 元件面视图

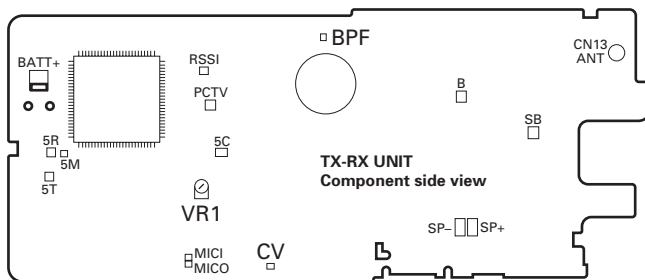

VR1 : Frequency adjustment
BPF : Band-pass wave form test point
CV : VCO lock voltage adjustment terminal

VR1 : 频率调整
BPF : 带通波形测试点
CV : VCO 锁定电压调整终端

Foil Side View

箔面视图

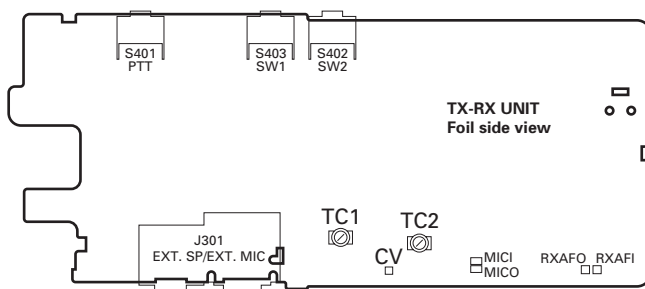

TC1 : Transmit VCO lock voltage adjustment
TC2 : Receive VCO lock voltage adjustment
CV : VCO lock voltage adjustment terminal

TC1 : 发射 VCO 锁定电压调整
TC2 : 接收 VCO 锁定电压调整
CV : VCO 锁定电压调整终端

Fig. 1 Adjustment points / 图 1 调整点

Frequency and signaling

The transceiver has been adjusted for the frequencies shown in the following table. When required, readjust them following the adjustment procedure to obtain the frequencies you want in actual operation.

Frequency (MHz) C5 type

Channel No.	RX Frequency	TX Frequency
1	380.050	380.100
2	370.050	370.100
3	389.950	389.900
4	380.000	380.000
5	380.200	380.200
6	380.400	380.400
7~16	—	—

Frequency (MHz) C6 type

Channel No.	RX Frequency	TX Frequency
1	360.050	360.100
2	350.050	350.100
3	369.950	369.900
4	360.000	360.000
5	360.200	360.200
6	360.400	360.400
7~16	—	—

频率和信令

频率设定调整如下表所示。当需要时，按照如下调整程序重新调整，以便获得您在实际操作时希望的频率。

频率 (MHz) C5 类型

信道号码	RX 频率	TX 频率
1	380.050	380.100
2	370.050	370.100
3	389.950	389.900
4	380.000	380.000
5	380.200	380.200
6	380.400	380.400
7~16	—	—

频率 (MHz) C6 类型

信道号码	RX 频率	TX 频率
1	360.050	360.100
2	350.050	350.100
3	369.950	369.900
4	360.000	360.000
5	360.200	360.200
6	360.400	360.400
7~16	—	—

ADJUSTMENT / 调整

Signaling

Signaling No.	RX	TX
1	None	None
2	None	100Hz Square Wave
3	QT 67.0Hz	QT 67.0Hz
4	QT 151.4Hz	QT 151.4Hz
5	QT 250.3Hz	QT 250.3Hz
6	DQT D023N	DQT D023N
7	DQT D754I	DQT D754I
8	DTMF 159D	DTMF 159D
9	None	DTMF tone 9

- Preparations for tuning the transceiver

Before attempting to tune the transceiver, connect the unit to a suitable power supply.

Whenever the transmitter is tuned, the unit must be connected to a suitable dummy load (i.e. power meter).

The speaker output connector must be terminated with a 8Ω dummy load and connected to an AC voltmeter and an audio distortion meter or a SINAD measurement meter at all times during tuning.

Adjustment Frequency

TEST CH	C5 type	
	RX Frequency	TX Frequency
Center	380.050MHz	380.100MHz
Low	370.050MHz	370.100MHz
High	389.950MHz	389.900MHz
Low'	375.050MHz	375.100MHz
High'	385.050MHz	385.100MHz

TEST CH	C6 type	
	RX Frequency	TX Frequency
Center	360.050MHz	360.100MHz
Low	350.050MHz	350.100MHz
High	369.950MHz	369.900MHz
Low'	355.050MHz	355.100MHz
High'	365.050MHz	365.100MHz

信令

信令号码	RX	TX
1	无	无
2	无	100Hz 方形波
3	QT 67.0Hz	QT 67.0Hz
4	QT 151.4Hz	QT 151.4Hz
5	QT 250.3Hz	QT 250.3Hz
6	DQT D023N	DQT D023N
7	DQT D754I	DQT D754I
8	DTMF 159D	DTMF 159D
9	无	DTMF 音频 9

- 调谐对讲机的准备

在调谐对讲机之前,把装置连接到规定的电源。

任何时候调整发射,装置必须连接到合适的假负载(比如功率表)。

在全部调谐过程中,扬声器输出端子必须连接8Ω假负载并连接到AC伏特计和音频失真仪或SINAD测试表。

调整频率

测试 CH	C5 类型	
	RX	TX
中心	380.050MHz	380.100MHz
低	370.050MHz	370.100MHz
高	389.950MHz	389.900MHz
低'	375.050MHz	375.100MHz
高'	385.050MHz	385.100MHz

测试 CH	C6 类型	
	RX	TX
中心	360.050MHz	360.100MHz
低	350.050MHz	350.100MHz
高	369.950MHz	369.900MHz
低'	355.050MHz	355.100MHz
高'	365.050MHz	365.100MHz

ADJUSTMENT / 调整

Common Section

Item	Condition	Measurement		Adjustment		Specifications/ Remark
		Test equipment	Terminal	Parts	Method	
1.Setting	1) BATT terminal voltage:7.5V 2) SSG standard modulation [Wide] MOD:1kHz,DEV:3kHz [Narrow] MOD:1kHz,DEV:1.5kHz					
2.VCO lock voltage RX	1) CH:High	Power meter DVM	ANT CV	TC2	3.0V	±0.1V
	2) CH:Low				Check	0.6V or more
3.VCO lock voltage TX	3) CH:High PTT:ON			TC1	3.0V	±0.1V
	4) CH:Low PTT:ON				Check	0.6V or more

Transmitter Section

Item	Condition	Measurement		Adjustment		Specifications/ Remark
		Test equipment	Terminal	Parts	Method	
1.Frequency Adjust	1) CH:High 2) PTT:ON	Frequency counter	ANT	VR1		High frequency ±50Hz
2.High power Adjust	TEST CH: Low Low' Center High' High (5 points) BATT terminal voltage:7.5V PTT:ON	Power meter Ammeter		Programming Software:KPG-87D		4.0W ±0.1W 1.9 A or less
						1.0W ±0.1W 0.9 A or less
3.Low power Adjust	TEST CH: Low Low' Center High' High (5 points) BATT terminal voltage:7.5V PTT:ON					
4. Max deviation Adjust [Wide]	TEST CH: Center Low High (3 points) AG:1kHz/150mV Deviation meter filter LPF:15kHz HPF:OFF PTT:ON	Power meter Deviation meter Oscilloscope AG AF VTVM	ANT SP/MIC connector		4.2kHz (According to the lager +,-)	±50Hz
	[Narrow]				TEST CH:Center PTT:ON	2.2kHz (According to the lager +,-)
5.VOX 1 Writing	TEST CH:Center AG:1kHz/45mV					

ADJUSTMENT / 调整

公共部分

项目	条件	测量		调整		规格 / 备注
		测试设备	终端	部件	方法	
1. 设置	1) BATT终端电压: 7.5V 2) SSG 标准调制 [宽] MOD:1kHz,DEV:3kHz [窄] MOD:1kHz,DEV:1.5kHz					
2. VCO 锁定电压 RX	1) CH: 高	功率表	ANT	TC2	3.0V	±0.1V
	2) CH: 低	DVM	CV		检查	0.6V 或以上
3. VCO 锁定电压 TX	3) CH: 高 PTT: ON			TC1	3.0V	±0.1V
	4) CH: 低 PTT: ON				检查	0.6V 或以上

发射部

项目	条件	测量		调整		规格 / 备注
		测试设备	终端	部件	方法	
1. 频率调整	1) CH: 高 2) PTT: ON	频率计	ANT	VR1		高频率 ±50Hz
2. 高功率调整	测试 CH: 低 低 / 中心 高 / 高 (5点) BATT 终端电压: 7.5V PTT: ON	功率表 电流表		编程软件: KPG-87D		4.0W ±0.1W 1.9A 或以下
3. 低功率调整	测试 CH: 低 低 / 中心 高 / 高 (5点) BATT 终端电压: 7.5V PTT: ON					1.0W ±0.1W 0.9A 或以下
4. 最大频偏调整 [宽]	测试 CH: 中心 低 高 (3点) AG: 1kHz / 150mV 频偏仪滤波器 LPF: 15kHz HPF: OFF PTT: ON	功率表 频偏仪 示波器 AG AF VTVM	ANT SP / MIC 连接器		4.2kHz (按照最大+,-)	±50Hz
	[窄]	测试 CH: 中心 PTT: ON			2.2kHz (按照最大+,-)	±50Hz
5. VOX 1 写入	测试 CH: 中心 AG: 1kHz / 45mV					

ADJUSTMENT / 调整

Item	Condition	Measurement		Adjustment		Specifications/ Remark
		Test equipment	Terminal	Parts	Method	
6. VOX 10 Writing	TEST CH:Center AG:1kHz/3.0mV	Power meter Deviation meter	ANT SP/MIC connector	Programming Software:KPG-87D		
7. DQT Balance Adjust [Wide]	TEST CH: Center Low High (3 points) LPF:3kHz HPF:OFF PTT:ON	Oscilloscope AG AF VTVM	ANT	Programming Software:KPG-87D	Make the demodulation wave into square waves	
[Narrow]	TEST CH:Center PTT:ON					
8. QT Deviation Adjust [Wide]	TEST CH: Center Low High (3 points) LPF:3kHz HPF:OFF PTT:ON				0.75kHz	±40Hz
[Narrow]	TEST CH: Center PTT:ON				0.40kHz	±40Hz
9. DQT Deviation Adjust [Wide]	TEST CH: Center Low High (3 points) LPF:3kHz HPF:OFF PTT:ON				0.75kHz	±40Hz
[Narrow]	TEST CH:Center PTT:ON				0.35kHz	±40Hz
10. DTMF Deviation Adjust [Wide]	TEST CH:Center LPF:15kHz HPF:OFF PTT:ON				3.0kHz	±100Hz
[Narrow]	TEST CH:Center PTT:ON				1.5kHz	±100Hz
11. MSK Deviation Adjust [Wide]	TEST CH: Center LPF:15kHz HPF:OFF PTT:ON				3.0kHz	±100Hz
[Narrow]	TEST CH:Center PTT:ON				1.5kHz	±100Hz

ADJUSTMENT / 调整

项目	条件	测量		调整		规格 / 备注
		测试设备	终端	部件	方法	
6. VOX 10 写入	测试 CH: 中心 AG: 1kHz / 3.0mV	功率表 频偏仪	ANT SP/MIC 连接器	编程软件: KPG-87D		
7. DQT 平衡调整 [宽]	测试 CH: 中心 低 高 (3点) LPF: 3kHz HPF: OFF PTT: ON	示波器 AG AF VTVM	ANT	编程软件: KPG-87D	把解调波调整为方波	
[窄]	测试 CH: 中心 PTT: ON					
8. QT 频偏调整 [宽]	测试 CH: 中心 低 高 (3点) LPF: 3kHz HPF: OFF PTT: ON				0.75kHz	± 40Hz
[窄]	测试 CH: 中心 PTT: ON				0.40kHz	± 40Hz
9. DQT 频偏调整 [宽]	测试 CH: 中心 低 高 (3点) LPF: 3kHz HPF: OFF PTT: ON				0.75kHz	± 40Hz
[窄]	测试 CH: 中心 PTT: ON				0.35kHz	± 40Hz
10. DTMF 频偏调整 [宽]	测试 CH: 中心 LPF: 15kHz HPF: OFF PTT: ON				3.0kHz	± 100Hz
[窄]	测试 CH: 中心 PTT: ON				1.5kHz	± 100Hz
11. MSK 频偏调整 [宽]	测试 CH: 中心 LPF: 15kHz HPF: OFF PTT: ON				3.0kHz	± 100Hz
[窄]	测试 CH: 中心 PTT: ON				1.5kHz	± 100Hz

ADJUSTMENT / 调整

Receiver Section

Item	Condition	Measurement		Adjustment		Specifications/ Remark
		Test equipment	Terminal	Parts	Method	
1. BPF Wave Adjust TK-3207 (C5)	(1)Center frequency Spectrum analyzer setting Center-f : 380MHz Span : 100MHz RBW : 300kHz VBW : 10kHz ATT : 10dB	Spectrum analyzer	ANT BPF	Programming Software: KPG-87D	Adjust the waveform as shown to the right.	<p>REF: -36.0 dBm MKR 380.0 MHz 5dB/ A_View Norm B_Blank Norm -47.688 dBm</p> <p>CENTER 380.0 MHz SPAN 100.0 MHz *RBW 300kHz *VBW 10kHz SWP 70ms *ATT 10dB</p>
	<p>REF: -36.0 dBm MKR 390.0 MHz 5dB/ A_View Norm B_Blank Norm -49.211 dBm</p> <p>CENTER 390.0 MHz SPAN 100.0 MHz *RBW 300kHz *VBW 10kHz SWP 70ms *ATT 10dB</p>					
	<p>REF: -36.0 dBm MKR 370.0 MHz 5dB/ A_View Norm B_Blank Norm -45.703 dBm</p> <p>CENTER 370.0 MHz SPAN 100.0 MHz *RBW 300kHz *VBW 10kHz SWP 70ms *ATT 10dB</p>					
TK-3207 (C6)	(1)Center frequency Spectrum analyzer setting Center-f : 360MHz Span : 100MHz RBW : 300kHz VBW : 10kHz ATT : 10dB					<p>REF: -36.0 dBm MKR 360.0 MHz 5dB/ A_View Norm B_Blank Norm -46.617 dBm</p> <p>CENTER 360.0 MHz SPAN 100.0 MHz *RBW 300kHz *VBW 10kHz SWP 70ms *ATT 10dB</p>
	<p>REF: -36.0 dBm MKR 370.0 MHz 5dB/ A_View Norm B_Blank Norm -46.617 dBm</p> <p>CENTER 370.0 MHz SPAN 100.0 MHz *RBW 300kHz *VBW 10kHz SWP 70ms *ATT 10dB</p>					
	<p>REF: -36.0 dBm MKR 350.0 MHz 5dB/ A_View Norm B_Blank Norm -46.906 dBm</p> <p>CENTER 350.0 MHz SPAN 100.0 MHz *RBW 300kHz *VBW 10kHz SWP 70ms *ATT 10dB</p>					

ADJUSTMENT / 调整

接收部

项目	条件	测量		调整		规格 / 备注
		测试设备	终端	部件	方法	
1. BPF 波形调整 TK-3207 (C5)	(1)中心频率 频谱分析仪设定 Center-f : 380MHz Span : 100MHz RBW : 300kHz VBW : 10kHz ATT : 10dB (2)高边频率 频谱分析仪设定 Center-f : 390MHz (3)低边频率 频谱分析仪设定 Center-f : 370MHz	频谱分析仪	ANT BPF	编程软件: KPG-87D	调整波形如 右图所示	
TK-3207 (C6)	(1)中心频率 频谱分析仪设定 Center-f : 360MHz Span : 100MHz RBW : 300kHz VBW : 10kHz ATT : 10dB (2)高边频率 频谱分析仪设定 Center-f : 370MHz (3)低边频率 频谱分析仪设定 Center-f : 350MHz					

ADJUSTMENT / 调整

Item	Condition	Measurement		Adjustment		Specifications/ Remark		
		Test equipment	Terminal	Parts	Method			
2. Sensitivity check [Wide]	TEST CH: Low Center High SSG output:-117 dBm(0.3μV) SSG MOD:3.0kHz	SSG DVM Oscilloscope AF VTVM	ANT		Check	12dB SINAD or more		
[Narrow]	TEST CH:Center SSG output:-115 dBm(0.4μV) SSG MOD:1.5kHz							
3. SQL1 (Threshold) writing [Wide]	TEST CH: Center Low High SSG output:-123 dBm(0.16μV) SSG MOD:3.0kHz				Programming Software: KPG-87D		Write	Squelch open
[Narrow]	TEST CH: Center SSG output:-122 dBm(0.18μV) SSG MOD:1.5kHz							
4. SQL9 (Tight) writing [Wide]	TEST CH: Center Low High SSG output:-117 dBm(0.3μV) SSG MOD:3.0kHz							
[Narrow]	TEST CH: Center SSG output:-117 dBm(0.3μV) SSG MOD:1.5kHz							
5. BATT Detection Writing	BATT terminal voltage:5.9V	DVM	ANT BATT terminal		Write	BATT terminal voltage:5.9V		

ADJUSTMENT / 调整

项目	条件	测量		调整		规格 / 备注
		测试设备	终端	部件	方法	
2. 灵敏度检查 [宽]	测试 CH: 低 中心 高 SSG 输出: -117 dBm (0.3 μ V) SSG MOD: 3kHz	SSG DVM 示波器 AF VTVM	ANT		检查	12dB SINAD 或 以上
	[窄]					
3. SQL1 (静噪阈值) 写入 [宽]	测试 CH: 中心 低 高 SSG 输出: -123 dBm (0.16 μ V) SSG MOD: 3.0kHz			编程软件: KPG-87D	写入	静噪开放
	[窄]					
4. SQL9 (深静噪) 写入 [宽]	测试 CH: 中心 低 高 SSG 输出: -117 dBm (0.3 μ V) SSG MOD: 3.0kHz					
	[窄]					
5. 电池检测写入	BATT 终端电压: 5.9V	DVM	ANT BATT 终端		写入	BATT 终端电压: 5.9V

TK-3207 PC BOARD / PC 板

TX-RX UNIT (X57-6890-XX) -21 : C -22 : C2 -24 : C6 -25 : C5
 Component side view (J72-0913-29)

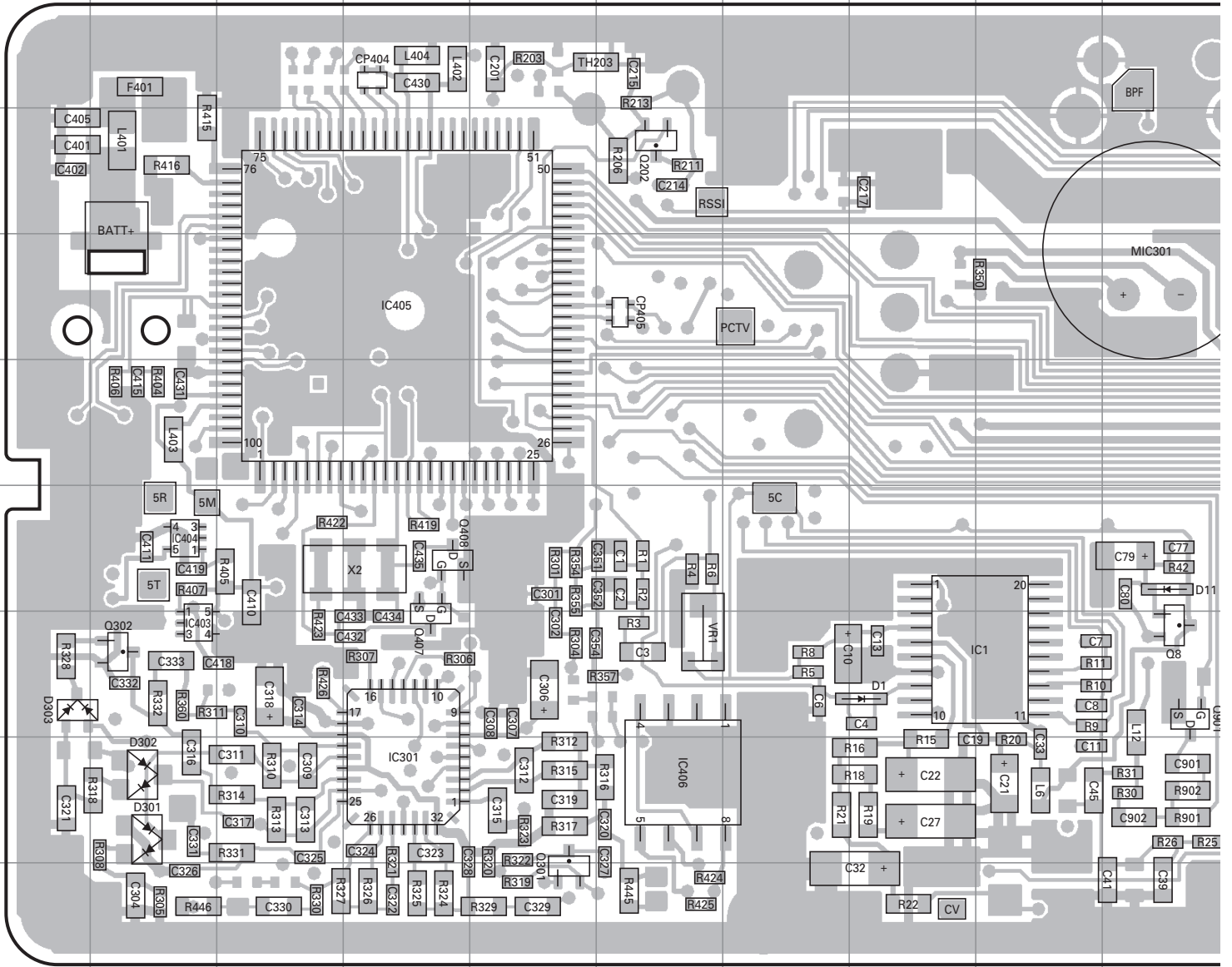

Ref. No.	Address	Ref. No.	Address	Ref. No.	Address	Ref. No.	Address
IC1	8I	Q104	5L	Q304	7P	D1	8H
IC101	4M	Q105	4K	Q305	8O	D11	7J
IC301	9D	Q107	4L	Q306	9P	D102	4M
IC302	8P	Q108	4L	Q316	9O	D301	9B
IC403	8B	Q109	5L	Q401	8R	D302	9B
IC404	7B	Q202	4F	Q402	8R	D303	8A
IC405	5D	Q301	10E	Q407	8D	D403	8R
IC406	9F	Q302	8B	Q408	7D	D404	8R
Q8	8J	Q303	7P	Q901	8J		

PC BOARD / PC 板 TK-3207

TX-RX UNIT (X57-6890-XX) -21 : C -22 : C2 -24 : C6 -25 : C5
 Component side view (J72-0913-29)

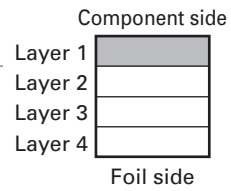
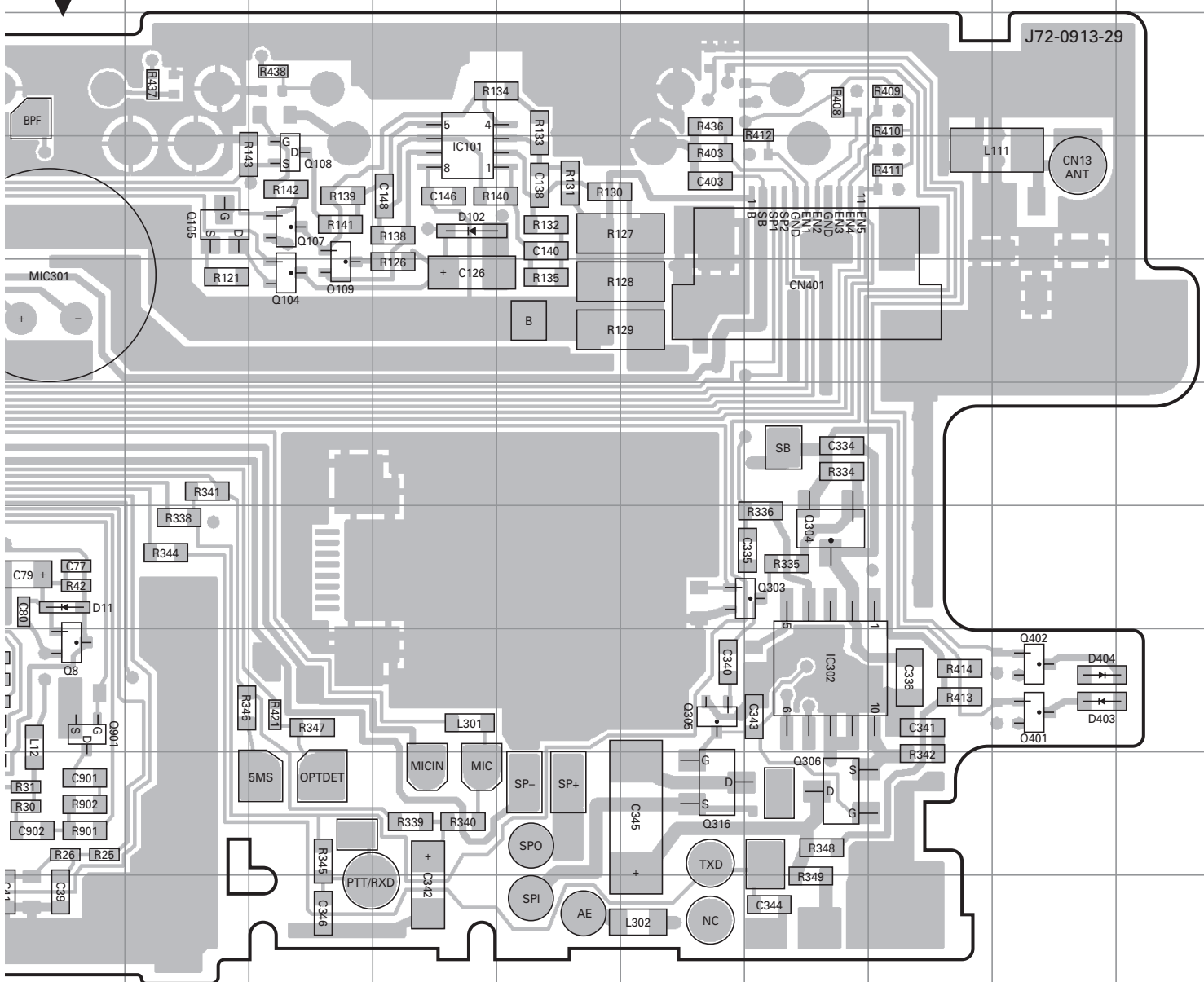

TK-3207 PC BOARD / PC 板

PC BOARD / PC 板 TK-3207

TX-RX UNIT (X57-6890-XX) -21 : C -22 : C2 -24 : C6 -25 : C5
Component side view (J72-0913-29)

TX-RX UNIT (X57-6890-XX) -21 : C -22 : C2 -24 : C6 -25 : C5
Component side view (J72-0913-29)

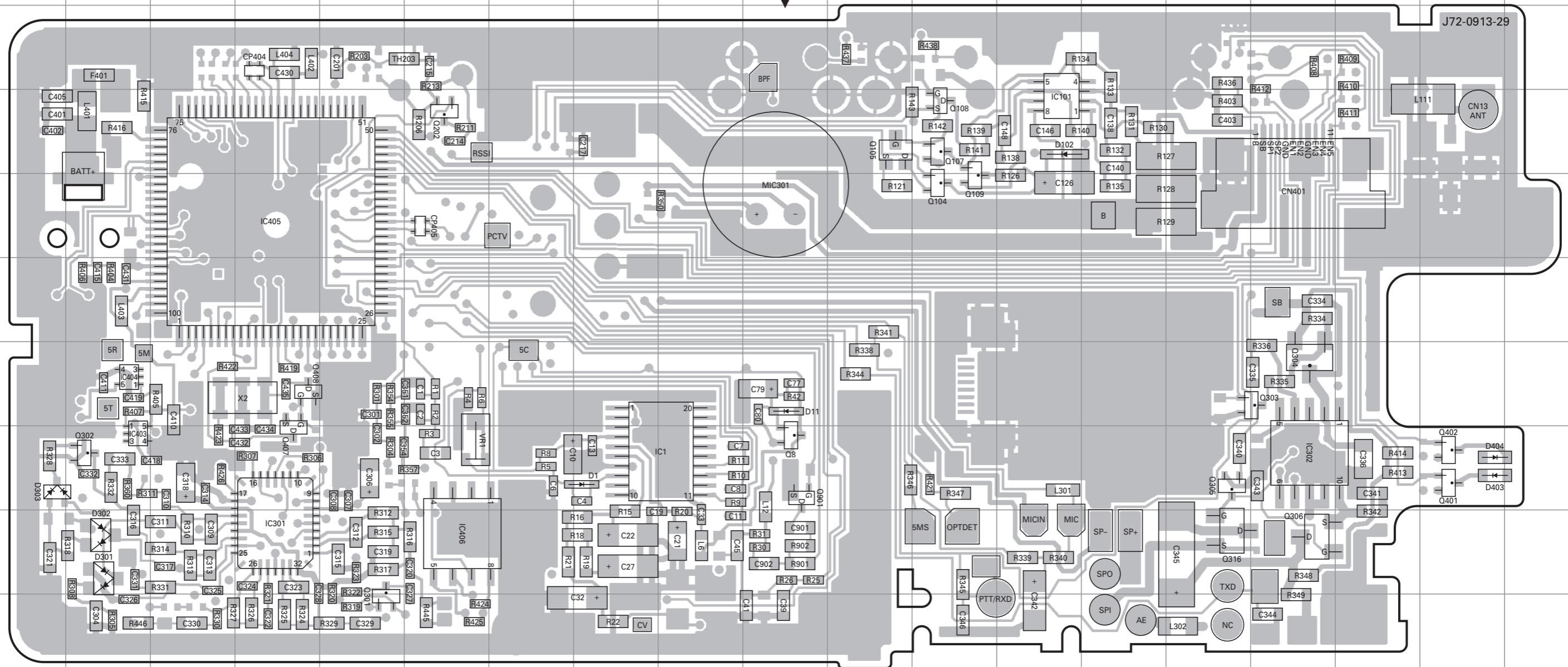

Ref. No.	Address	Ref. No.	Address	Ref. No.	Address	Ref. No.	Address
IC1	8I	Q104	5L	Q304	7P	D1	8H
IC101	4M	Q105	4K	Q305	8O	D11	7J
IC301	9D	Q107	4L	Q306	9P	D102	4M
IC302	8P	Q108	4L	Q316	9O	D301	9B
IC403	8B	Q109	5L	Q401	8R	D302	9B
IC404	7B	Q202	4F	Q402	8R	D303	8A
IC405	5D	Q301	10E	Q407	8D	D403	8R
IC406	9F	Q302	8B	Q408	7D	D404	8R
Q8	8J	Q303	7P	Q901	8J		

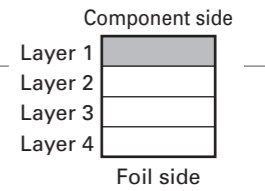

TK-3207 PC BOARD / PC 板

TX-RX UNIT (X57-6890-XX) -21 : C -22 : C2 -24 : C6 -25 : C5
 Foil side view (J72-0913-29)

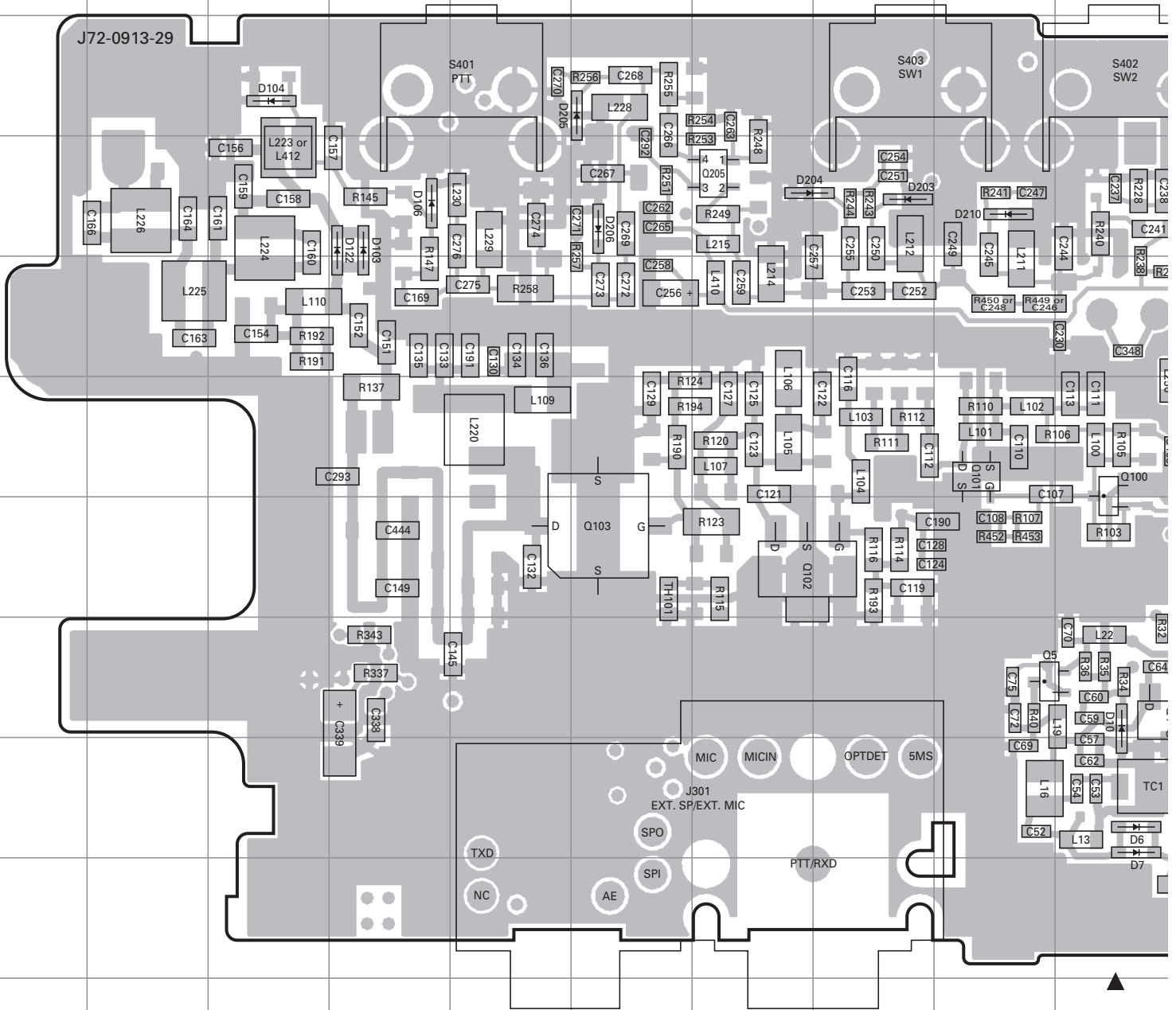

Ref. No.	Address	Ref. No.	Address	Ref. No.	Address	Ref. No.	Address	Ref. No.	Address	Ref. No.	Address
IC201	5N	Q6	8K	Q204	4K	D5	10L	D104	3C	D210	4I
IC401	9R	Q7	9L	Q205	4G	D6	9J	D106	4D	D401	7R
IC402	8R	Q9	6L	Q403	8R	D7	9J	D122	4D	D402	4R
Q1	7O	Q100	6J	Q404	7R	D8	10L	D202	6K	D405	9P
Q2	8L	Q101	6I	Q405	9R	D9	10L	D203	4H		
Q3	9M	Q102	7G	D2	9K	D10	8J	D204	4G		
Q4	8J	Q103	7F	D3	10M	D101	6K	D205	3F		
Q5	8I	Q203	4N	D4	9J	D103	4D	D206	4F		

PC BOARD / PC 板 TK-3207

TX-RX UNIT (X57-6890-XX) -21 : C -22 : C2 -24 : C6 -25 : C5
Foil side view (J72-0913-29)

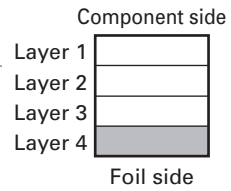
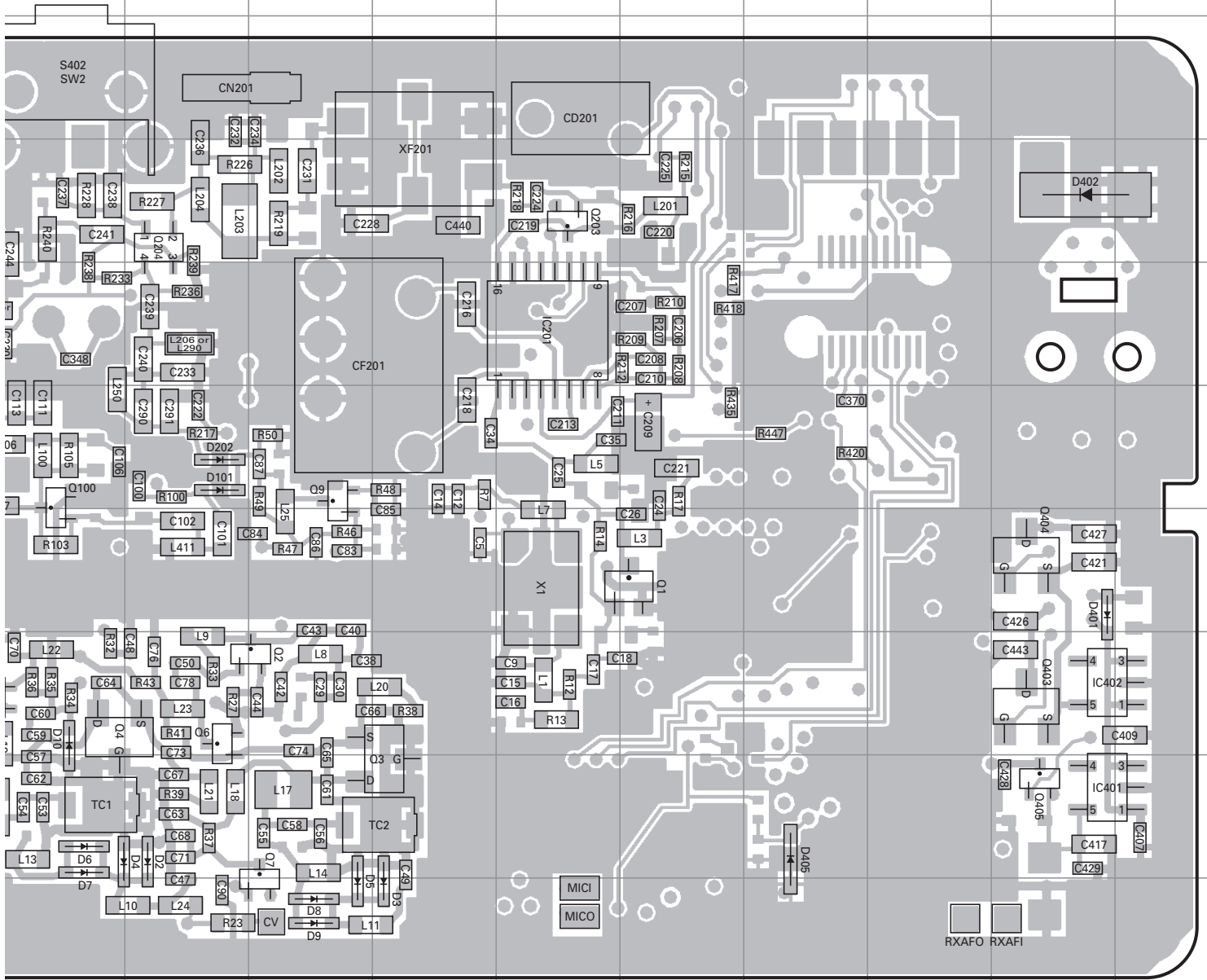

TK-3207 PC BOARD / PC 板

PC BOARD / PC 板 TK-3207

TX-RX UNIT (X57-6890-XX) -21 : C -22 : C2 -24 : C6 -25 : C5
Foil side view (J72-0913-29)

TX-RX UNIT (X57-6890-XX) -21 : C -22 : C2 -24 : C6 -25 : C5
Foil side view (J72-0913-29)

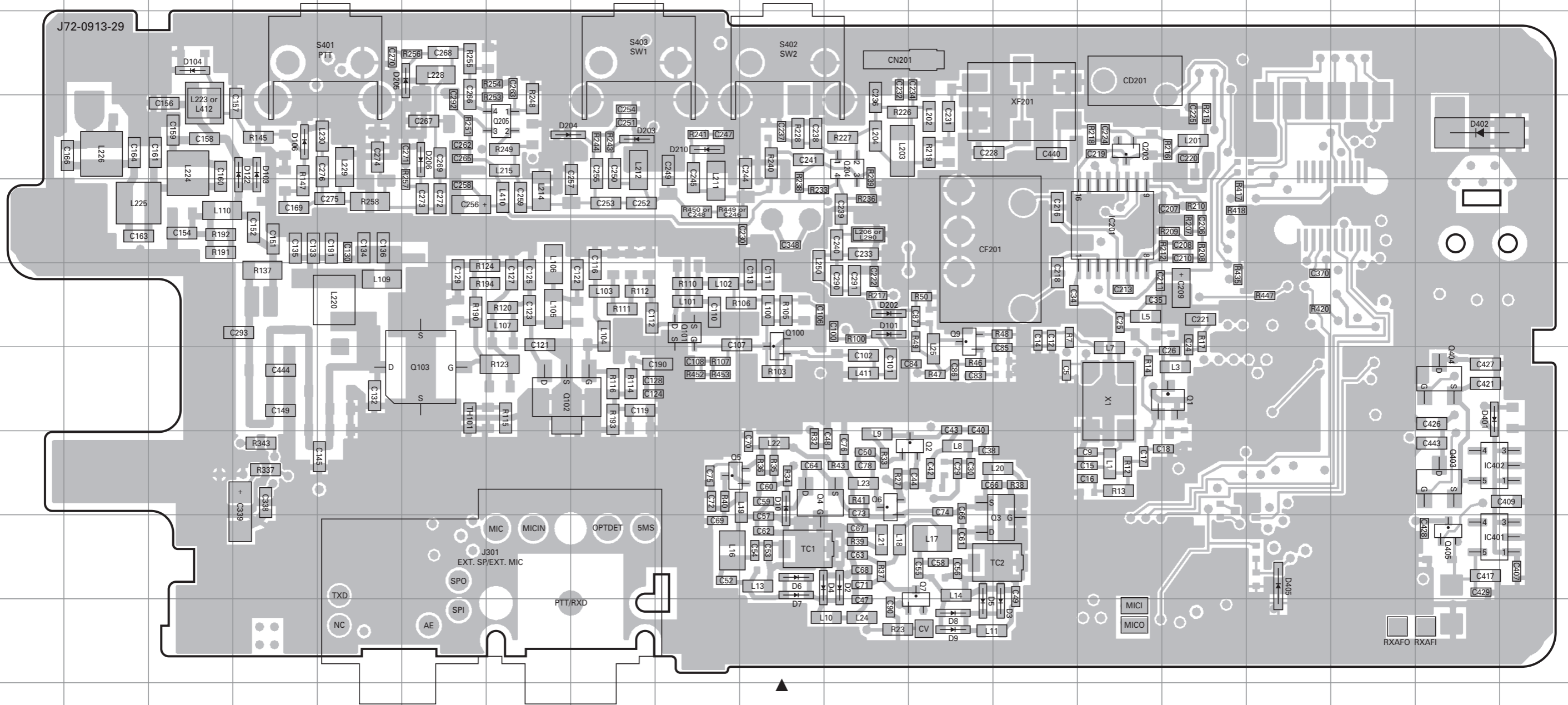

Ref. No.	Address	Ref. No.	Address	Ref. No.	Address	Ref. No.	Address	Ref. No.	Address	Ref. No.	Address
IC201	5N	Q6	8K	Q204	4K	D5	10L	D104	3C	D210	4I
IC401	9R	Q7	9L	Q205	4G	D6	9J	D106	4D	D401	7R
IC402	8R	Q9	6L	Q403	8R	D7	9J	D122	4D	D402	4R
Q1	7O	Q100	6J	Q404	7R	D8	10L	D202	6K	D405	9P
Q2	8L	Q101	6I	Q405	9R	D9	10L	D203	4H		
Q3	9M	Q102	7G	D2	9K	D10	8J	D204	4G		
Q4	8J	Q103	7F	D3	10M	D101	6K	D205	3F		
Q5	8I	Q203	4N	D4	9J	D103	4D	D206	4F		

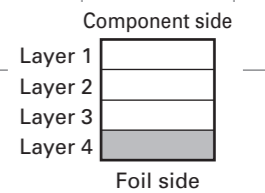

TK-3207 SCHEMATIC DIAGRAM / 原理图

TX-RX UNIT (X57-6890-XX)

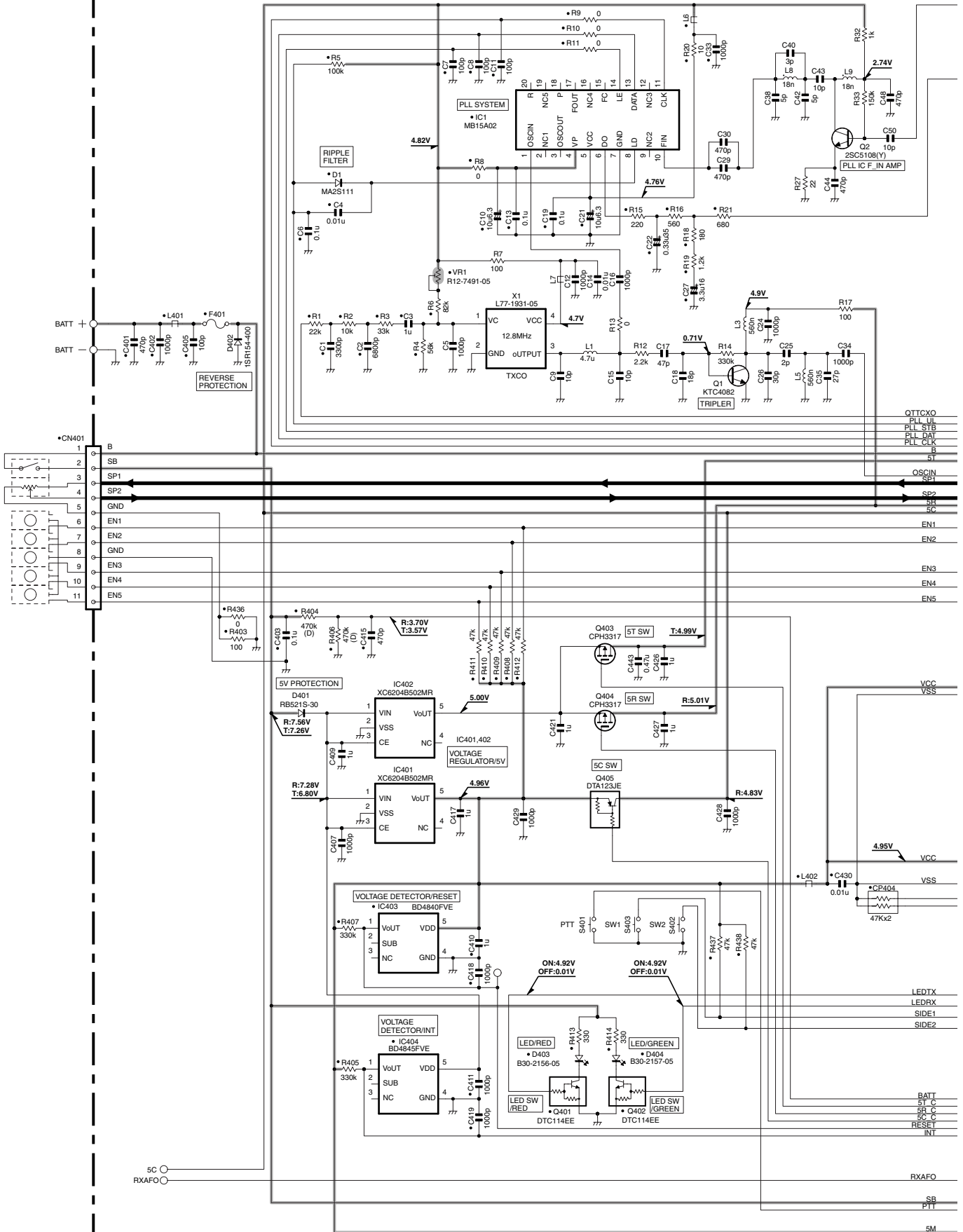

SCHEMATIC DIAGRAM / 原理图 TK-3207

TX-RX UNIT (X57-6890-XX)

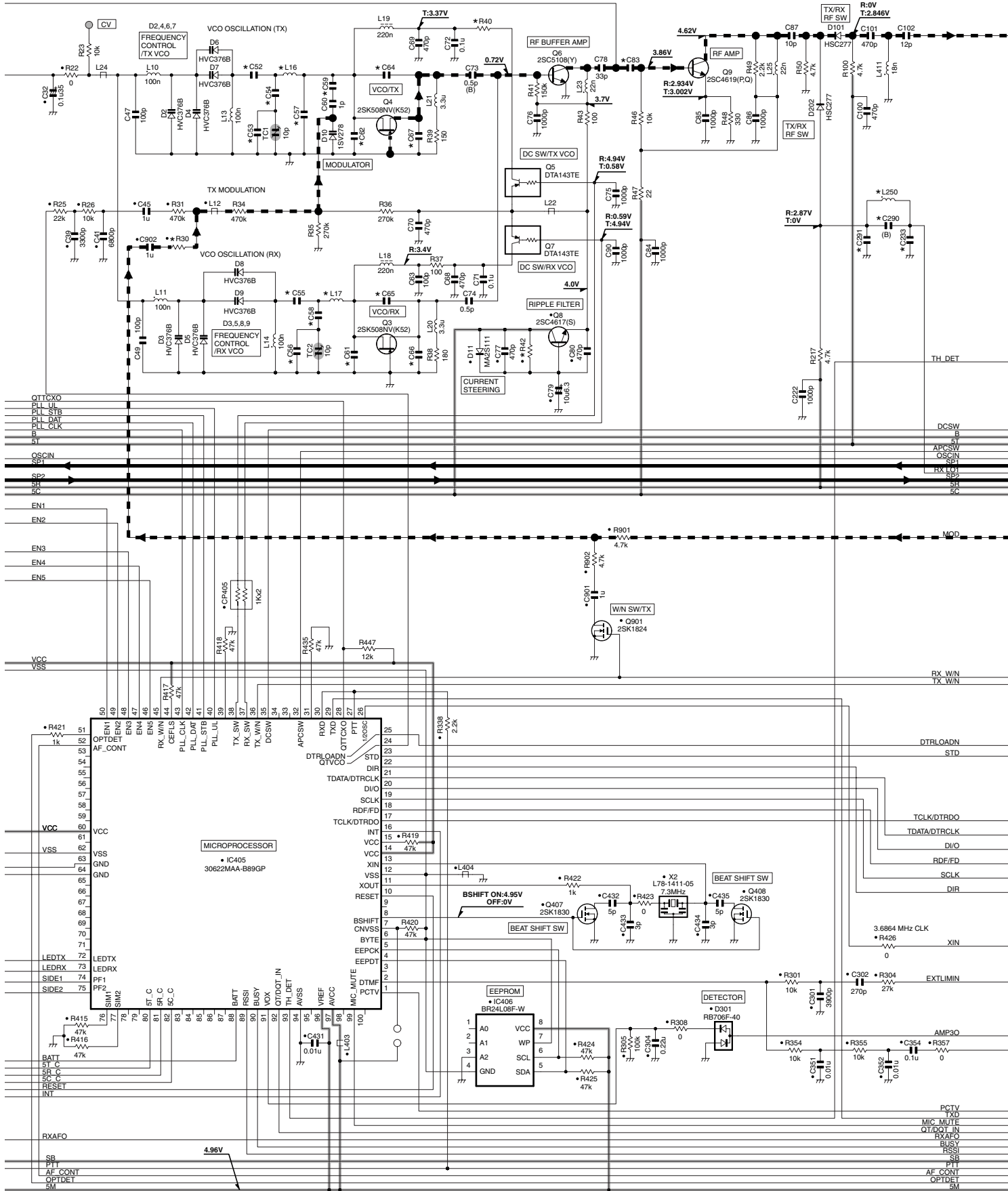

SCHEMATIC DIAGRAM / 原理图 TK-3207

X57-6890-XX	L16	L17	L100	L101	L107	L206	L211	L212	L214	L223	L228	L229	L230	L250	L290	L412	C52	C53	C54	C55	C56	C57	C58	C59	C61	C62	C64	C65	C66	C67	C83	C107	C116	C121	C125	C127	C132	
-21	C	22n	27n	15n	15n	1.2n	NO	8.2n	8.2n	8.2n	L34-4572-05	8.2n	8.2n	39n	18n	30n	NO	12p	NO	6p	12p	NO	NO	6p	1p	3p	2p	5p	7p	7p	5p	15p	6p	11p	NO	6p	20p	20p
-22	C2	27n	33n	33n	22n	NO	39n	NO	8.2n	8.2n	NO	8.2n	8.2n	56n	18n	NO	L34-4564-05	11p	4p	7p	12p	5p	0.5p	7p	1.5p	4p	3p	4p	5p	5p	4p	15p	7p	3p	12p	8p	NO	39p
-24	C6	39n	47n	27n	22n	NO	56n	NO	12n	12n	L34-4572-05	12n	12n	72n	15n	NO	NO	11p	5p	9p	12p	11p	1.5p	5p	3p	3p	4p	5p	4p	5p	8p	12p	NO	24p	NO	20p		
-25	C5	39n	47n	27n	22n	NO	56n	NO	12n	12n	L34-4572-05	12n	12n	68n	15n	NO	NO	11p	NO	6p	11p	NO	0.5p	6p	1.5p	5p	3p	4p	4p	4p	15p	8p	12p	NO	24p	NO	20p	

X57-6890-XX	C145	C149	C151	C152	C156	C157	C158	C159	C160	C161	C164	C166	C169	C233	C240	C244	C245	C246	C247	C248	C249	C250	C252	C253	C255	C257	C267	C268	C269	C273	C274	C275	C276	C290	C291	C292	C293	C444	
-21	C	18p	7p	NO	20p	4p	1p	100p	2p	2p	5p	5p	0.75p	6p	6p	3.5p	2.5p	22p	2p	470p	2p	4.5p	22p	1p	1.5p	22p	4p	2.5p	22p	2p	22p	NO	2.5p	4p	2p	6p	470p	NO	NO
-22	C2	30p	7p	7p	30p	3p	4p	100p	2p	2p	5p	5p	0.75p	10p	6p	1p	NO	NO	NO	NO	NO	5p	22p	1.5p	2p	22p	7p	6p	22p	2p	22p	4p	2p	4p	2p	6p	470p	NO	2p
-24	C6	27p	10p	NO	27p	9p	3.5p	1000p	1p	1.5p	6p	6p	10p	1p	3p	6p	10p	1p	NO	NO	NO	470p	NO	3.5p	27p	1p	1.5p	27p	6p	6p	27p	2p	2p	4.5p	5p	10p	1000p	4p	NO
-25	C5	27p	NO	NO	27p	6p	2.5p	1000p	1p	1.5p	6p	6p	3p	4.5p	10p	1p	NO	NO	NO	470p	NO	3p	27p	1p	1.5p	27p	6p	5p	27p	4p	1.5p	4p	5p	10p	1000p	4p	10p		

X57-6890-XX	R30	R40	R42	R103	R106	R120	R194	R241	R449	R450	D210	D405	L225	
-21	C	33k	150	10k	47k	22	NO	47k	1.0M	NO	NO	HVC355B	NO	L34-4564-05
-22	C2	33k	100	4.7k	10k	120	0	22k	NO	0	0	NO	NO	L34-4564-05
-24	C6	27k	100	4.7k	47k	22	0	47k	1.0M	0	0	HVC355B	KD23.3V	L34-4565-05
-25	C5	27k	100	4.7k	47k	22	0	47k	1.0M	0	0	HVC355B	KD23.3V	L34-4565-05

Note : The components marked with a dot (●) are parts of layer 1.

TX-RX UNIT (X57-6890-XX)

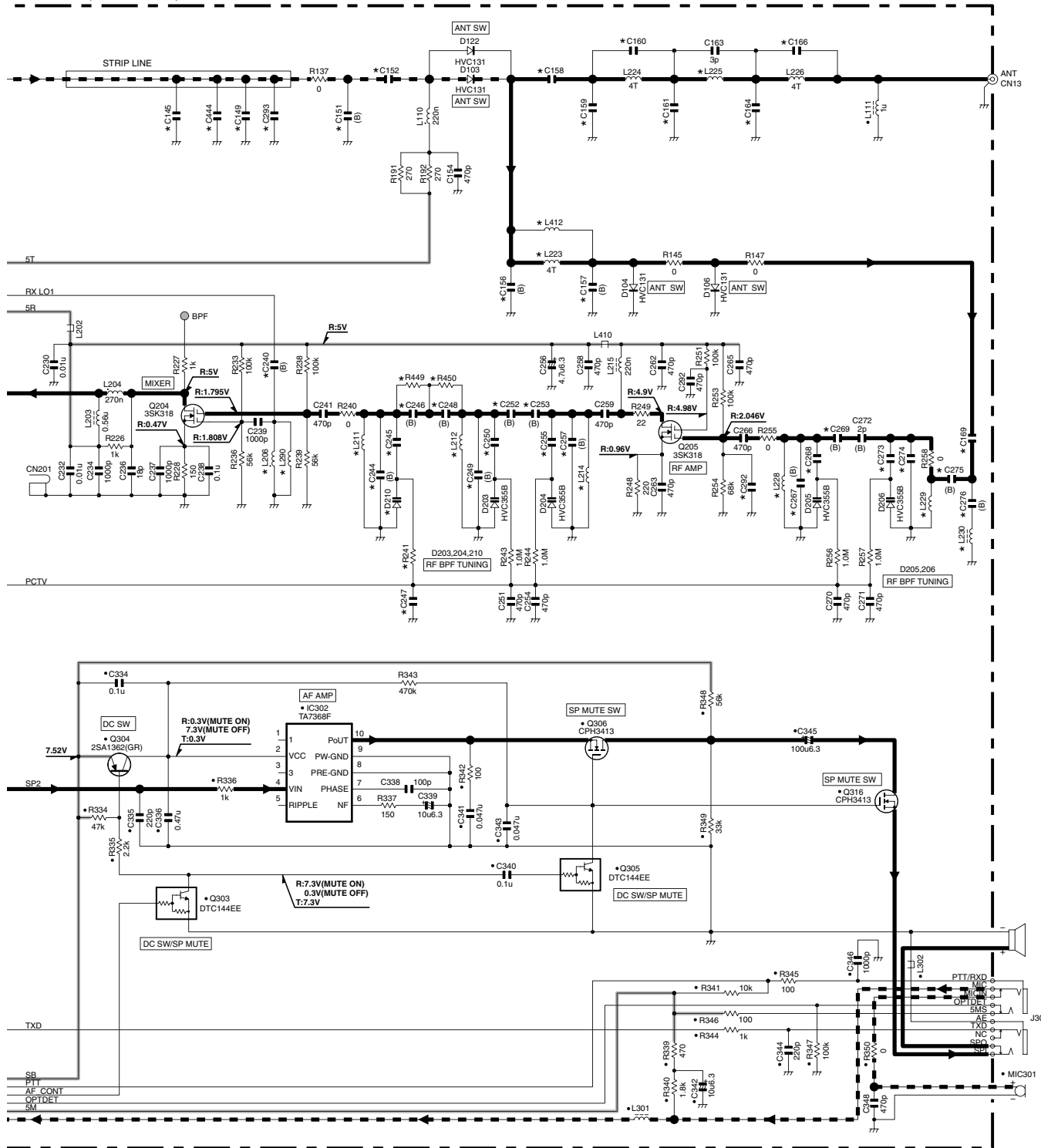

TK-3207 SCHEMATIC DIAGRAM / 原理图

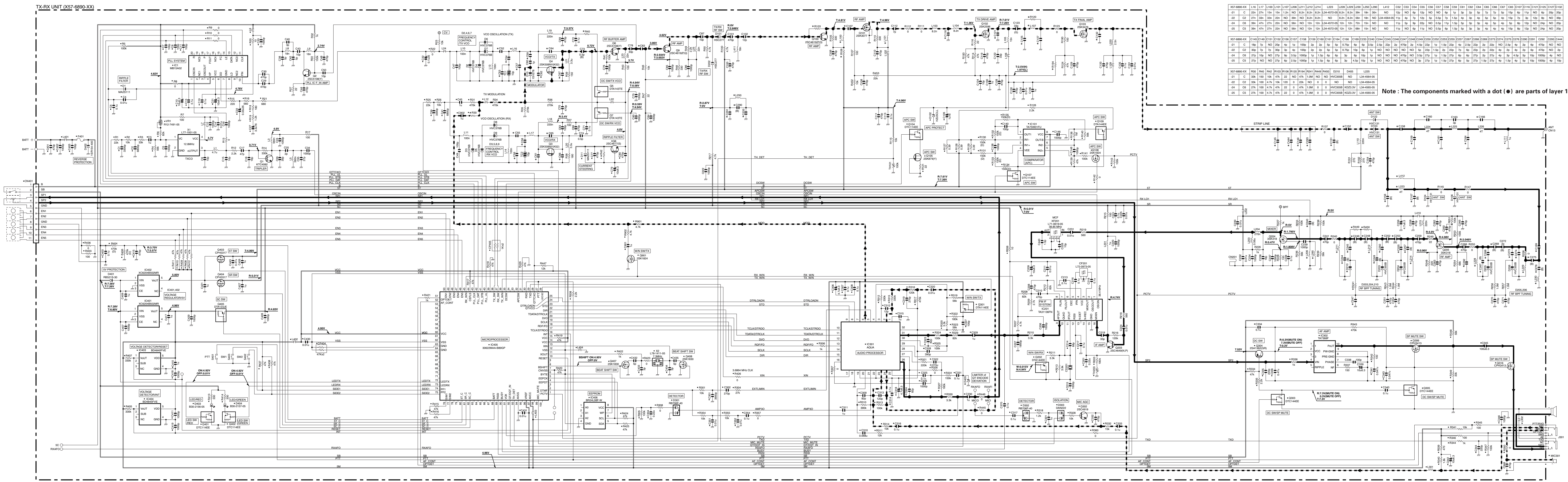

BLOCK DIAGRAM / 方块图

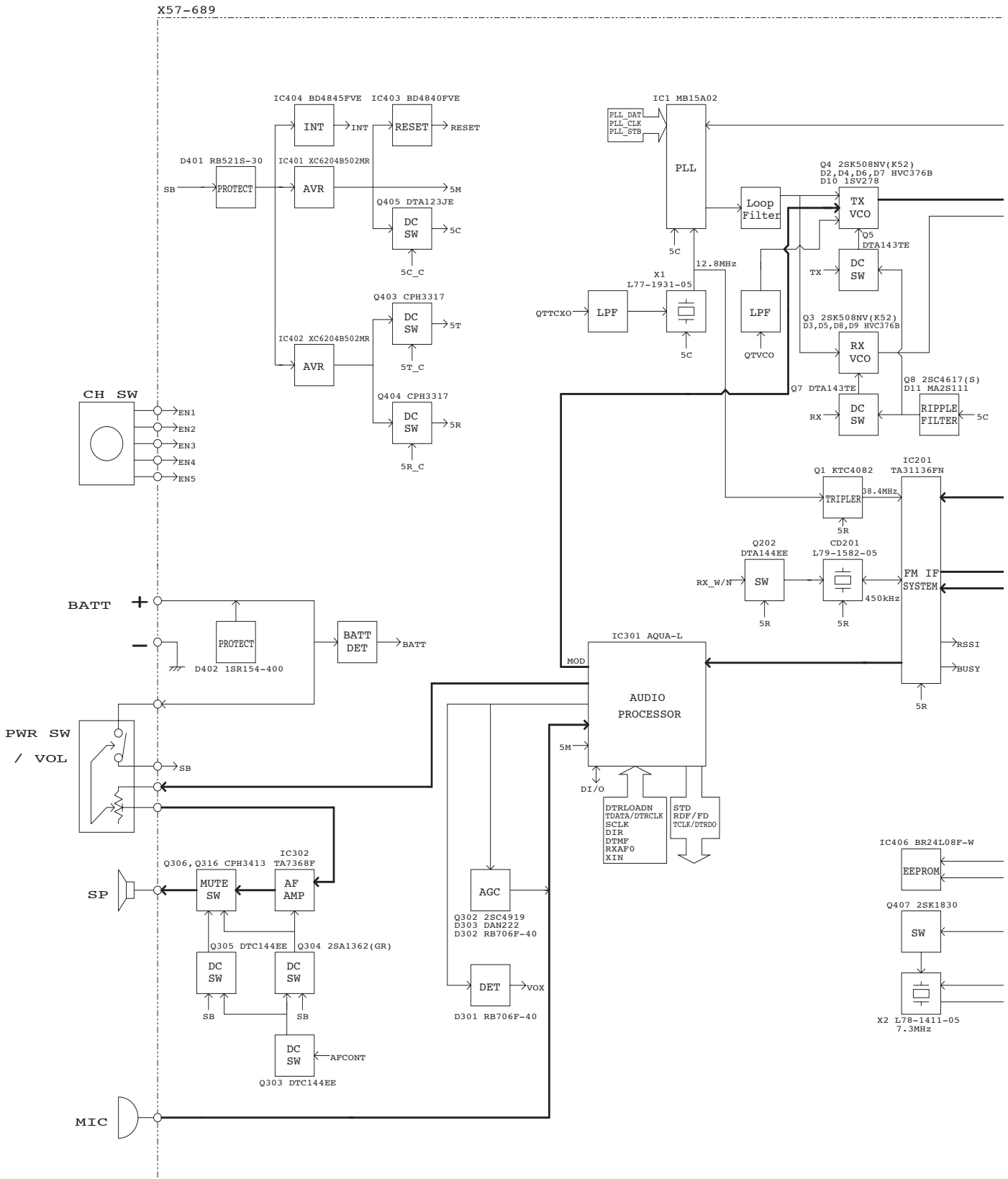

BLOCK DIAGRAM / 方块图

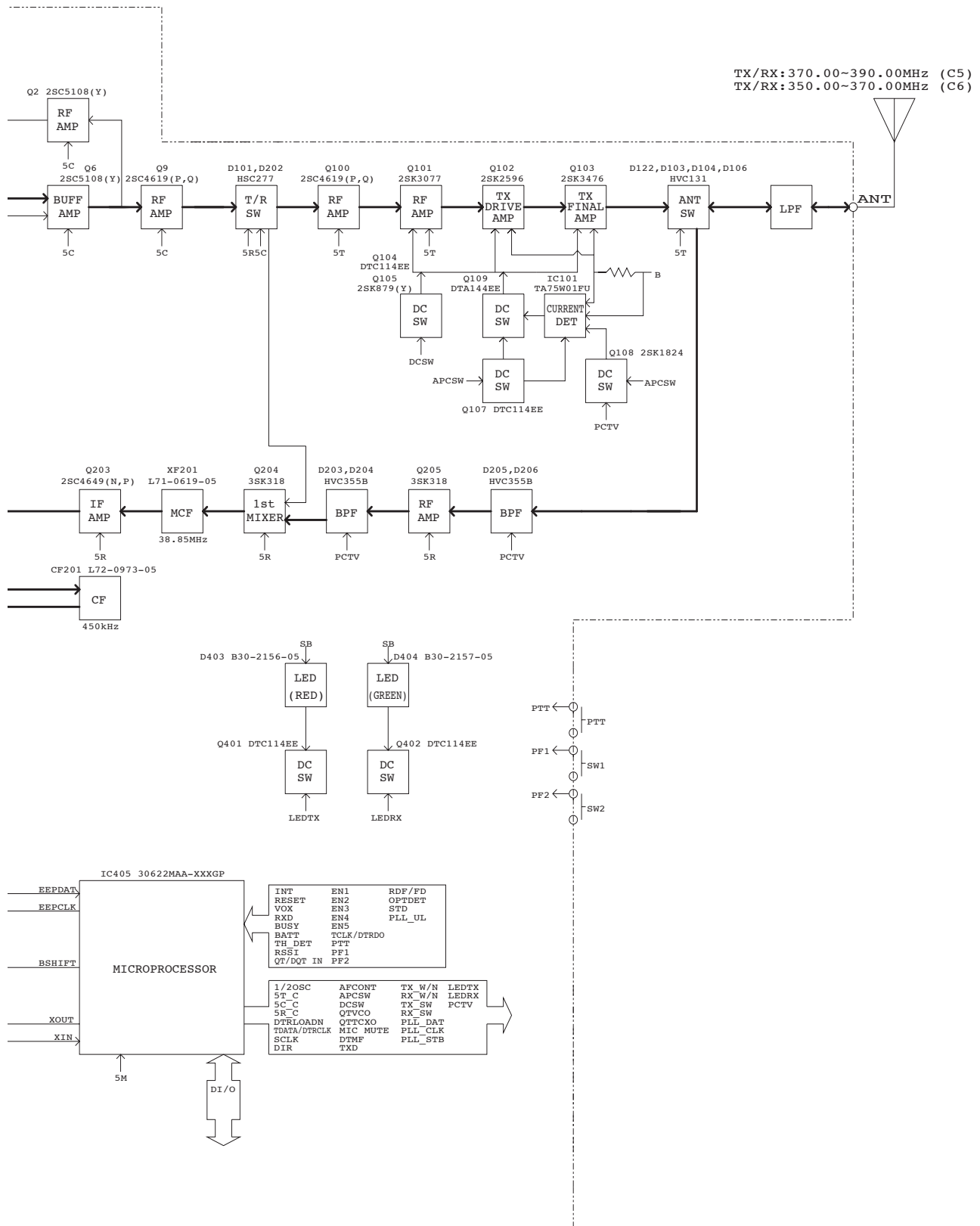

LEVEL DIAGRAM / 电平图

Receiver Section / 接收部

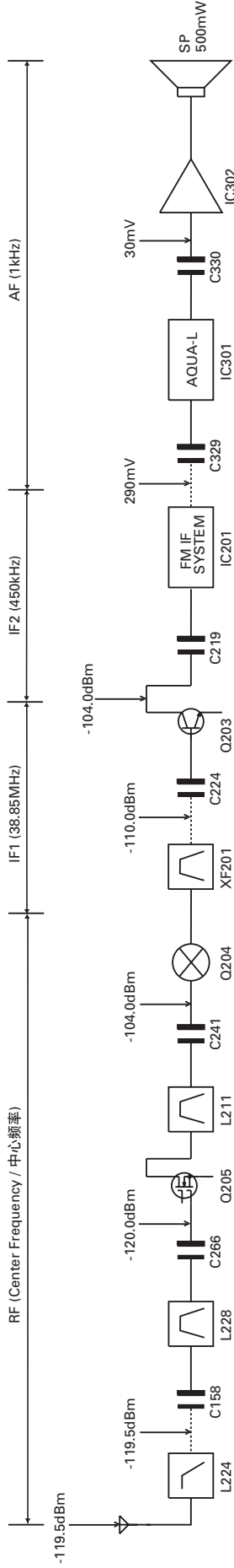

如要在 AF 部测量, 则连接 AC 电平表。(天线输入:
-53dBm, 1kHz FM, 3kHz DEV(宽))
如要在 RF 部测量, 请使用 1000pF 耦合电容器。
(图中显示了获得 12dB SINAD 所需的 SSG 输入值,
没有本地电平。)

To make measurements in the AF section, connect
the AC level meter. (ANT input: -53dBm, 1kHz FM,
3kHz DEV (WIDE).)
In the RF section, use 1000pF coupling capacitor.
(The display shows the SSG input value required to
obtain 12dB SINAD without local level.)

Transmitter Section / 发射部

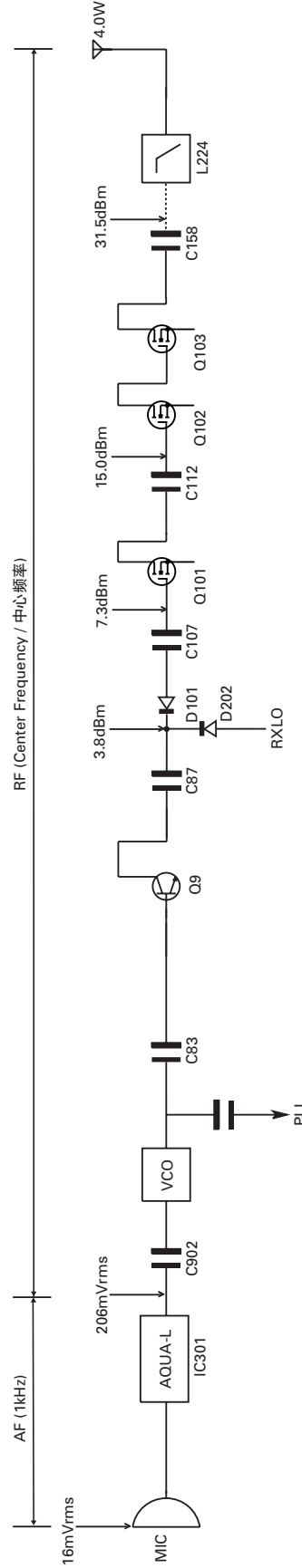

AG is set to the MIC input becomes 3kHz DEV at
1kHz MOD. (WIDE)

如要在 AF 部测量, 则连接 AC 电平表。
如要在 RF 部测量, 请使用 1000pF 耦合电容器。

In the RF section, use 1000pF coupling capacitor.

AG 被设置成话筒输入得到 3kHz DEV 在 1kHz MOD
(宽)。

如要在 AF 部测量, 则连接 AC 电平表。
如要在 RF 部测量, 请使用 1000pF 耦合电容器。

SPECIFICATIONS

General

Frequency Range	370~390MHz (C5) 350~370MHz (C6)
Number of Channels	Max. 16
Channel Spacing	25kHz (Wide) 12.5kHz (Narrow)
PLL Channel Stepping	5kHz, 6.25kHz
Operating Voltage	7.5 V DC \pm 20%
Battery Life	More than 14 hours at 4 watts (5-5-90 duty cycle with KNB-29N battery) More than 9 hours at 4 watts (5-5-90 duty cycle with KNB-30A battery)
Operating Temperature Range	-30°C to +60°C
Frequency Stability	\pm 2.5ppm (-30°C to +60°C)
Channel Frequency Spread	20MHz (C5, C6)
Dimensions and Weight (Dimensions not including protrusions)	
Radio Only	54 (2-1/8) W x 122 (4-13/16) H x 21.1 (13/16) D mm (inches) 160g (0.35lbs)
With KNB-29N (1500mAh battery)	54 (2-1/8) W x 122 (4-13/16) H x 33 (1-5/16) D mm (inches) 360g (0.79lbs)
With KNB-30A (1100mAh battery)	54 (2-1/8) W x 122 (4-13/16) H x 33 (1-5/16) D mm (inches) 340g (0.75lbs)

Receiver (Measurements made per TIA/EIA-603)

Sensitivity	
EIA 12dB SINAD	0.25 μ V (Wide)/0.28 μ V (Narrow)
Selectivity	70dB (Wide)/60dB (Narrow)
Intermodulation	65dB (Wide)/60dB (Narrow)
Spurious Response	60dB
Audio Power Output	500mW at 8 Ω less than 10% distortion

Transmitter (Measurements made per TIA/EIA-603)

RF Power Output	4W/1W
Spurious and Harmonics	65dB
Modulation	16K0F3E (Wide)/11K0F3E (Narrow)
FM Noise	45dB (Wide)/40dB (Narrow)
Audio Distortion	Less than 5%

概述

频率范围	370~390MHz (C5) 350~370MHz (C6)
频道数	最大 16
信道间距	25kHz (宽) 12.5kHz (窄)
PLL 频道步进	5kHz, 6.25kHz
电池电压	7.5 V 直流 ±20%
电池寿命	4W 时长于 14 个小时 (使用 KNB-29N 电池 5-5-90 工作周期) 4W 时长于 9 个小时 (使用 KNB-30A 电池 5-5-90 工作周期)
温度范围	-30°C 到 +60°C (-22° F 到 + 140° F)
频率稳定性	± 2.5ppm (-30°C 到 +60°C)
信道频率扩展	20MHz (C5, C6)
尺寸和重量 (尺寸大小不包括突出部分)	
仅对讲机时	54 (2-1/8) 宽 x 122 (4-13/16) 高 x 21.1 (13/16) 长 mm (英寸) 160g (0.35 lbs)
带有 KNB-29N (1500mAh 电池)	54 (2-1/8) 宽 x 122 (4-13/16) 高 x 33 (1-5/16) 长 mm (英寸) 360g (0.79 lbs)
带有 KNB-30A (1100mAh 电池)	54 (2-1/8) 宽 x 122 (4-13/16) 高 x 33 (1-5/16) 长 mm (英寸) 340g (0.75 lbs)

接收部 (根据标准 TIA / EIA-603 测定)

灵敏度	
EIA 12dB SINAD	0.25µV (宽) / 0.28µV (窄)
选择性	70dB (宽) / 60dB (窄)
互调	65dB (宽) / 60dB (窄)
杂散响应抗扰性	60dB
音频功率输出	8 Ω 负载为 500mW, 失真小于 10%

发射部 (根据标准 TIA / EIA-603 测定)

射频功率输出	4W / 1W
杂散射频分量	65dB
调制	16K0F3E (宽) / 11K0F3E (窄)
FM 噪音	45dB (宽) / 40dB (窄)
音频失真	低于 5%

Kenwood Corporation

2967-3, Ishikawa-machi, Hachioji-shi, Tokyo, 192-8525 Japan

Kenwood U.S.A. Corporation

P.O. BOX 22745, 2201 East Dominguez Street, Long Beach, CA 90801-5745, U.S.A.

Kenwood Electronics Canada Inc.

6070 Kestrel Road, Mississauga, Ontario, Canada L5T 1S8

Kenwood Electronics Deutschland GmbH

Rembrücker Str. 15, 63150 Heusenstamm, Germany

Kenwood Electronics Belgium N.V.

Leuvensesteenweg 248 J, 1800 Vilvoorde, Belgium

Kenwood Electronics France S.A.

L'Etoile Paris Nord 2, 50 Allée des Impressionnistes, Bp 58416 Villepinte, 95944 Roissy Ch De Gaulle Cedex

Kenwood Electronics UK Limited

KENWOOD House, Dwight Road, Watford, Herts., WD18 9EB United Kingdom

Kenwood Electronics Europe B.V.

Amsterdamseweg 37, 1422 AC Uithoorn, The Netherlands

Kenwood Electronics Italia S.p.A.

Via G. Sirtori, 7/9 20129 Milano, Italy

Kenwood Ibérica, S.A.

Bolivia, 239-08020 Barcelona, Spain

Kenwood Electronics Australia Pty. Ltd.

(A.C.N. 001 499 074)

16 Giffnock Avenue, Centrecourt Estate, North Ryde, N.S.W. 2113 Australia

Kenwood Electronics (Hong Kong) Ltd.

Unit 3712-3724, Level 37, Tower one Metroplaza, 223 Hing Fong Road, Kwai Fong, N.T., Hong Kong

Kenwood Electronics Singapore Pte Ltd

1 Ang Mo Kio Street 63, Singapore 569110

